

# Installation and Operation of Portable Motor Operator

## Table of Contents

Section	Page	Section	Page
<b>Introduction</b>		<b>Components</b>	
Qualified Persons . . . . .	2	General . . . . .	6
Read this Instruction Sheet . . . . .	2	<b>Installation</b>	
Retain this Instruction Sheet. . . . .	2	Installing the Portable Motor Operator . . . . .	7
Proper Application . . . . .	2	<b>Operation</b>	
Warranty . . . . .	2	Opening, Closing, or Grounding. . . . .	12
<b>Safety Information</b>		<b>Removal</b>	
Understanding Safety-Alert Messages. . . . .	3	Removing the Portable Motor Operator . . . . .	14
Following Safety Instructions . . . . .	3	<b>Troubleshooting</b>	
Replacement Instructions and Labels . . . . .	3	If the Remote Control READY Light	
Location of Safety Labels . . . . .	4	Does Not Light. . . . .	15
<b>Safety Precautions</b> . . . . .	5	Fault Conditions on the S&C-Furnished Ac-Input	
		Power Supply . . . . .	15



## Introduction

---

### Qualified Persons

#### **WARNING**

The equipment and components covered by this publication must be installed, operated, and maintained by qualified persons who are knowledgeable in the installation, operation, and maintenance of underground electric power distribution equipment along with the associated hazards. A qualified person is one who is trained and competent in:

- The skills and techniques necessary to distinguish exposed live parts from nonlive parts of electrical equipment
- The skills and techniques necessary to determine the proper approach distances corresponding to the voltages to which the qualified person will be exposed
- The proper use of the special precautionary techniques, personal protective equipment, insulating and shielding materials, and insulated tools for working on or near exposed energized parts of electrical equipment

These instructions are intended only for such qualified persons. They are not intended to be a substitute for adequate training and experience in safety procedures for this type of equipment.

### Read this Instruction Sheet

#### **NOTICE**

Thoroughly and carefully read this instruction sheet and all materials included in the product's instruction handbook before installing or operating your Visa Underground Distribution Switchgear and portable motor operator. Be familiar with the Safety Information and Safety Precautions on pages 3 through 5. The latest version of this publication is available online in PDF format at [sandc.com/en/support/product-literature/](http://sandc.com/en/support/product-literature/).

### Retain this Instruction Sheet

This instruction sheet is a permanent part of your Vista Underground Distribution Switchgear. Designate a location where you can easily retrieve and refer to this publication.

### Proper Application

#### **WARNING**

The equipment in this publication is only intended for a specific application. The application must be within the ratings furnished for the equipment. Ratings for the Visa Underground Distribution Switchgear are listed in the ratings table in Specification Bulletin 681-31. The ratings are also on nameplate affixed to the product.

### Warranty

The warranty and/or obligations described in S&C's Price Sheet 150 "Standard Conditions of Sale—Immediate Purchasers in the United States" (or Price Sheet 153, "Standard Conditions of Sale—Immediate Purchasers Outside the United States"), plus any special warranty provisions, as set forth in the applicable product-line specification bulletin, are exclusive. The remedies provided in the former for breach of these warranties shall constitute the immediate purchaser's or end user's exclusive remedy and a fulfillment of the seller's entire liability. In no event shall the seller's liability to the immediate purchaser or end user exceed the price of the specific product that gives rise to the immediate purchaser's or end user's claim. All other warranties, whether express or implied or arising by operation of law, course of dealing, usage of trade or otherwise, are excluded. The only warranties are those stated in Price Sheet 150 (or Price Sheet 153), and THERE ARE NO EXPRESS OR IMPLIED WARRANTIES OF MERCHANTABILITY OR FITNESS FOR A PARTICULAR PURPOSE. ANY EXPRESS WARRANTY OR OTHER OBLIGATION PROVIDED IN PRICE SHEET 150 (OR PRICE SHEET 153) IS GRANTED ONLY TO THE IMMEDIATE PURCHASER AND END USER, AS DEFINED THEREIN. OTHER THAN AN END USER, NO REMOTE PURCHASER MAY RELY ON ANY AFFIRMATION OF FACT OR PROMISE THAT RELATES TO THE GOODS DESCRIBED HEREIN, ANY DESCRIPTION THAT RELATES TO THE GOODS, OR ANY REMEDIAL PROMISE INCLUDED IN PRICE SHEET 150 (OR PRICE SHEET 153.)

**Understanding Safety-Alert Messages**

Several types of safety-alert messages may appear throughout this instruction sheet and on labels and tags attached to the Vista Underground Distribution Switchgear and portable motor operator. Familiarize yourself with these types of messages and the importance of these various signal words:

<b>⚠ DANGER</b>
“DANGER” identifies the most serious and immediate hazards that will likely result in serious personal injury or death if instructions, including recommended precautions, are not followed.
<b>⚠ WARNING</b>
“WARNING” identifies hazards or unsafe practices that can result in serious personal injury or death if instructions, including recommended precautions, are not followed.
<b>⚠ CAUTION</b>
“CAUTION” identifies hazards or unsafe practices that can result in minor personal injury if instructions, including recommended precautions, are not followed.
<b>NOTICE</b>
“NOTICE” identifies important procedures or requirements that can result in product or property damage if instructions are not followed.

**Following Safety Instructions**

If you do not understand any portion of this instruction sheet and need assistance, contact your nearest S&C Sales Office or S&C Authorized Distributor. Their telephone numbers are listed on S&C’s website [sandc.com](http://sandc.com), or call the S&C Global Monitoring and Support Center at 1-888-762-1100.

<b>NOTICE</b>	
Read this instruction sheet thoroughly and carefully before installing a portable motor operator to Vista Underground Distribution Switchgear.	

**Replacement Instructions and Labels**

If additional copies of this instruction sheet are needed, contact your nearest S&C Sales Office, S&C Authorized Distributor, S&C Headquarters, or S&C Electric Canada Ltd.

It is important that any missing, damaged, or faded labels on the equipment be replaced immediately. Replacement labels are available by contacting your nearest S&C Sales Office, S&C Authorized Distributor, S&C Headquarters, or S&C Electric Canada Ltd.

# Safety Information

---

## Location of Safety Labels



### Reorder Information for Safety Information

Location	Safety Alert Message	Description	Part Number
A	<b>⚠ CAUTION</b>	Never Drill Into Housing	G-10043
B	<b>⚠ CAUTION</b>	Not Designed for Permanent Installation	G-10047

**⚠ DANGER**



The portable motor operator used with the Vista Underground Distribution System contains high voltage. Failure to observe the precautions below will result in serious personal injury or death.

Some of these precautions may differ from company operating procedures and rules. Where a discrepancy exists, users should follow their company's operating procedures and rules.

- |   |  |
|---|--|
| <ol style="list-style-type: none"> <li>1. <b>QUALIFIED PERSONS.</b> Access to switches and controls must be restricted only to qualified persons. See the "Qualified Persons" section on page 2.</li> <li>2. <b>SAFETY PROCEDURES.</b> Always follow safe operating procedures and rules.</li> <li>3. <b>PERSONAL PROTECTIVE EQUIPMENT.</b> Always use suitable protective equipment, such as rubber gloves, rubber mats, hard hats, safety glasses, and flash clothing, in accordance with safe operating procedures and rules.</li> <li>4. <b>SAFETY LABELS.</b> Do not remove or obscure any of the "DANGER," "WARNING," "CAUTION," or "NOTICE" labels.</li> <li>5. <b>OPERATING MECHANISM AND BASE.</b> Stored energy operating mechanism and switch base contain fast-moving parts that can severely injure fingers. Do not remove or disassemble operating mechanism, or remove access panel on switch base unless directed by S&amp;C Electric Company.</li> <li>6. <b>ENERGIZED COMPONENTS.</b> Always consider all parts live until de-energized, tested, and grounded.</li> </ol> | <ol style="list-style-type: none"> <li>7. <b>GROUNDING.</b> Before energization and at all times when energized, the switch base and control unit enclosure must be connected to suitable earth ground in accordance with the S&amp;C instruction sheet furnished with this device.<br/><br/>The switch base ground must also be connected to the system neutral. If the system neutral is not present, proper precautions must be taken to ensure that the local earth ground cannot be severed or removed.</li> <li>8. <b>LOAD-INTERRUPTER SWITCH POSITION.</b> Always confirm the <b>Open/Close</b> position of load-interrupter switches by visually observing the indicator.<br/><br/>Interrupters and terminal pads may be energized from either terminal.<br/><br/>Interrupters and terminal pads may be energized with the interrupters in any position.</li> <li>9. <b>MAINTAINING PROPER CLEARANCE.</b> Always maintain proper clearance from energized components.</li> </ol> |
|---|--|

# Components

---

## General

The portable motor operator has been carefully designed to allow users to power operate, from a remote location, load-interrupter switches and single-pole or three-pole fault interrupters in Vista Underground Distribution Switchgear. The portable motor operator is a lightweight operator that can quickly and easily be attached without tools to UnderCover, vault-mounted, and pad-mounted styles of Vista switchgear. The portable motor operator is not intended for permanent installation.

The portable motor operator includes a carrying case and 50-foot (1524-cm) cable with remote controls, and it uses power supplied by one of the following:

- A user-furnished 24-Volt battery and battery charger
- An S&C-furnished 24-Volt battery and battery charger
- An S&C-furnished ac-input power supply



Portable motor operator



Carrying case



Remote control



S&C-furnished ac-input power supply



S&C-furnished 24-Volt battery and battery charger



## Installing the Portable Motor Operator

Follow these steps to install the portable motor operator:

- STEP 1.** Observe the position of the operating disk and selector lever on the load-interrupter disk switch way or single-pole or three-pole fault-interrupter way to which the portable motor operator is to be installed. Remove padlocks. See Figure 1.

If operation is to be from the **Closed** position to the **Open** position or vice versa, place the selector lever in the **Grounded** position as shown in Figure 1. In the far-right position, the selector lever allows operation between the **Closed** and **Open** positions; inadvertent operation directly from the **Closed** position to the **Grounded** position is prevented.

If operation is to be from the **Open** position to the **Grounded** position or vice versa, place the selector lever in the **Blade Closed** position. See Figure 2. In the far-left position, the selector lever allows operation between the **Open** and **Grounded** positions; inadvertent operation directly from the **Grounded** position to the **Closed** position is prevented.

### **⚠ WARNING**

**ALWAYS** make sure the cables connected to the load-interrupter switch or fault interrupter are de-energized before grounding the switchgear. **Failure to follow this precaution can result in a flashover and equipment damage.**

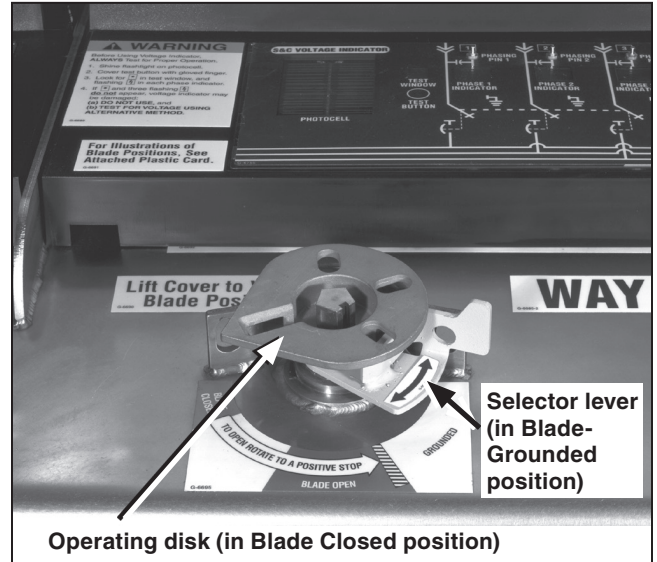

Figure 1. Observe the position of the operating disk and selector lever.

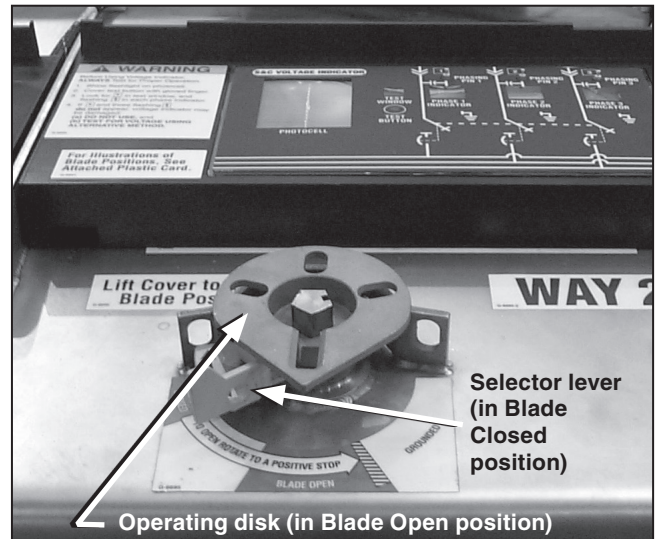

Figure 2. Selector lever in the Blade Closed position.

## Installation

Before operating to the **Grounded** position, always make sure the cables connected to the load-interrupter switch or fault interrupter are de-energized. Check for voltage using the POTENTIAL indicator (option suffix “-L1” or “-L2”), if furnished, as instructed under the “Checking for Voltage Using Optional Voltage Indication” section in Instruction Sheet 681-510, 682-510, or 683-510.

**STEP 2.** Adjust the position lever of the portable motor operator to correspond with the position of the operating disk observed in Step 1. See Figure 3.

**STEP 3.** While holding the latching lever in the **Open** position, lift the portable motor operator and place on the operating shaft of the gear. See Figure 4.

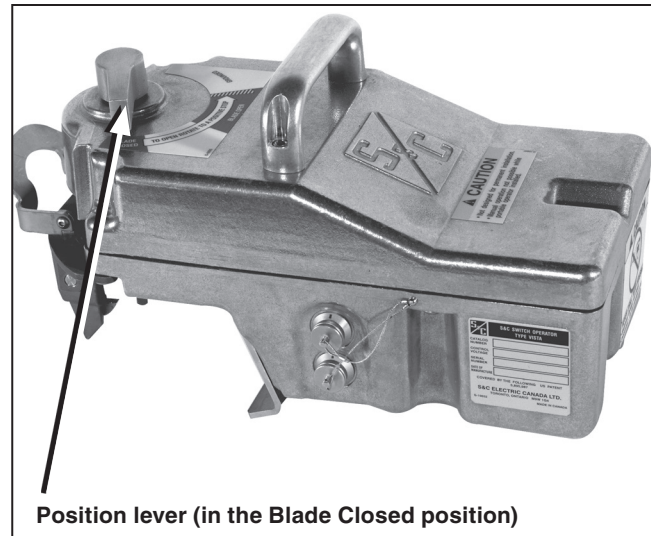

Figure 3. Adjusting the position lever of the portable motor operator.

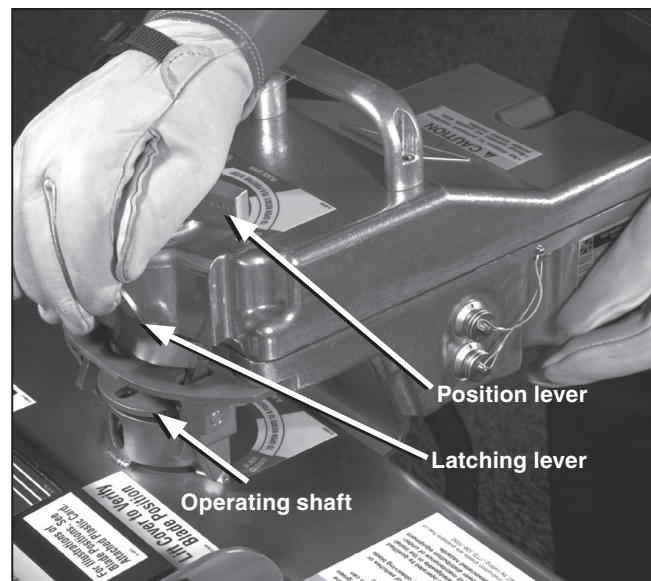

Figure 4. Positioning the portable motor operator on the operating shaft.



**NOTICE**

The position lever of the portable motor operator may need to be manually rotated slightly from side to side to allow the output shaft to line up with the operating shaft on the gear.

- STEP 4.** When the portable motor operator is seated on the operating shaft of the gear, release the latching lever. Make sure the portable motor operator is fully seated and both latches have latched onto the stop ring on the tank. See Figure 5.
- STEP 5.** Connect the cable with remote controls to the portable motor operator. See Figure 6.

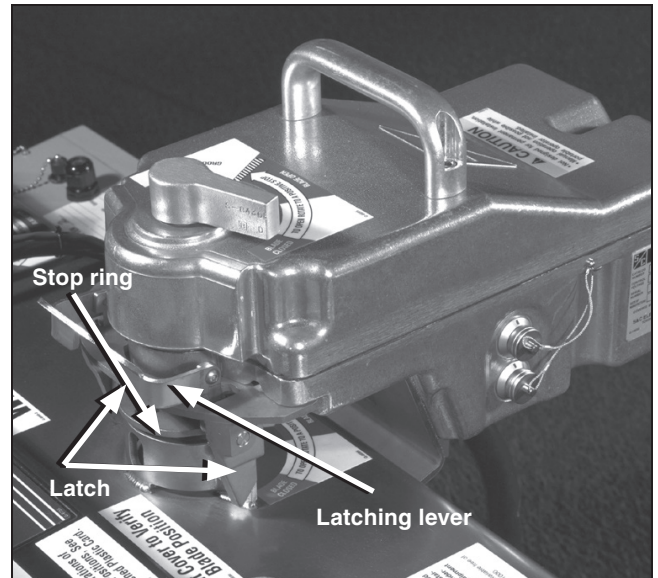

**Figure 5.** Checking to make sure the portable motor operator is fully seated and latched.

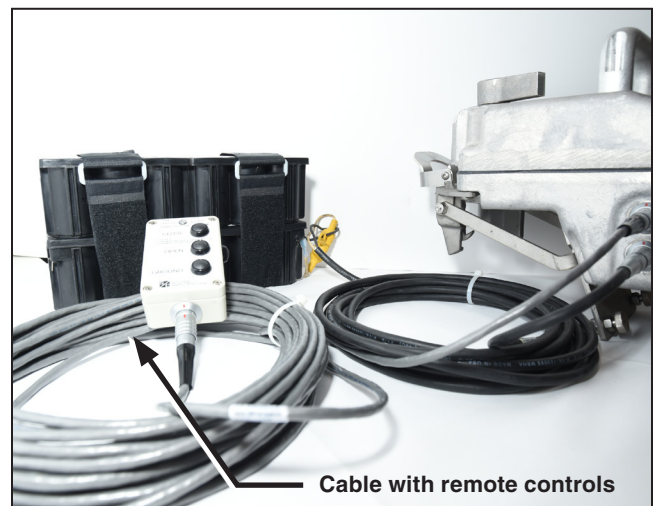

**Figure 6.** The connecting cable with remote controls.

# Installation

**STEP 6.** Connect the control power cable to the portable motor operator and to the control power source. See Figures 7 through 9.

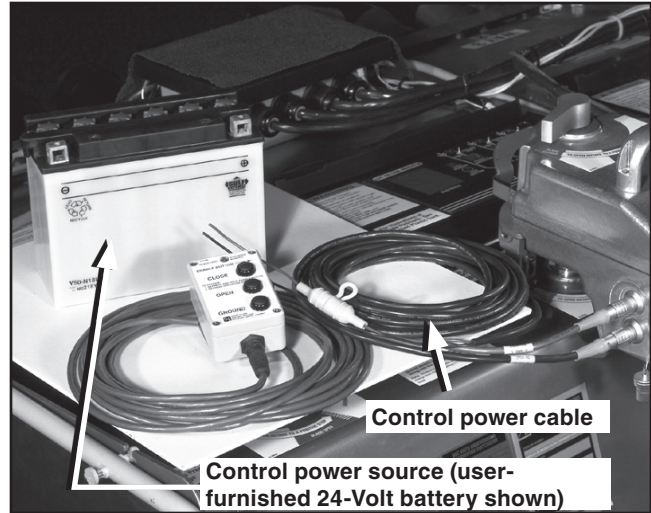

Figure 7. Connecting the control power cable to user-furnished 24-Volt battery.

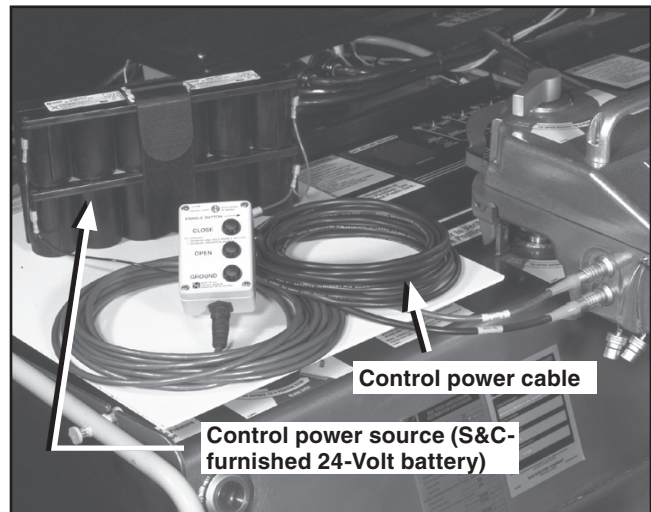

Figure 8. Connecting the control power cable to S&C-furnished 24-Volt battery.

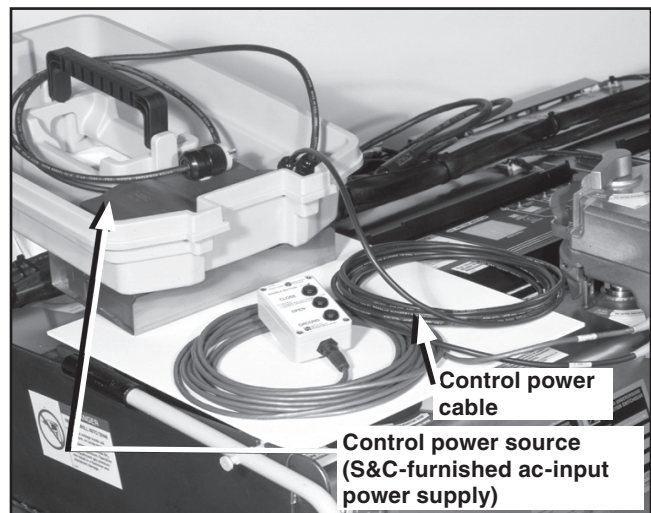

Figure 9. Connecting the control power cable to S&C-furnished ac-input power supply.

**STEP 7.** If the power source is an S&C-furnished ac-input power supply, insert its three-prong plug into a grounded 120-Vac power receptacle. Be sure to check that the LEDs labeled “DC 24V” and “LOAD 2L+” are lit on the power supply, as shown in Figure 10. If they are not lit, refer to Table 1 on page 13 and to the “Troubleshooting” section on page 15.

**STEP 8.** Check that the READY light is lit on the remote control. See Figure 11. It will remain continuously lit while control voltage is supplied to the operator. If the READY light is not lit or is blinking rapidly, refer to the “Troubleshooting” section on page 15.

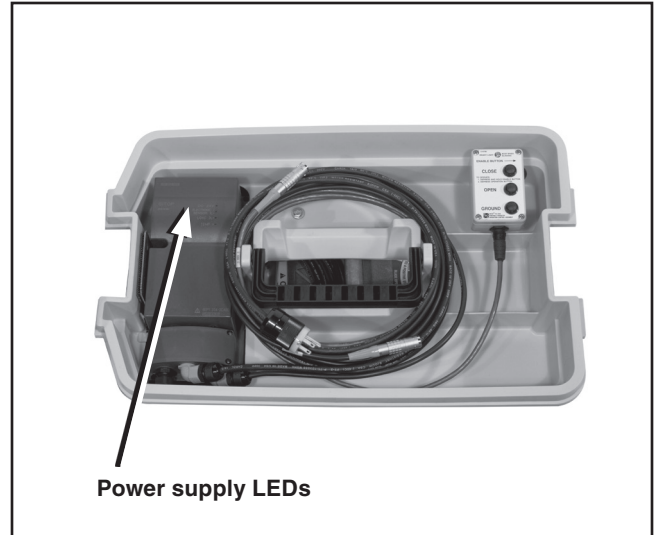

Figure 10. LEDs on the S&C-furnished ac-input power supply.

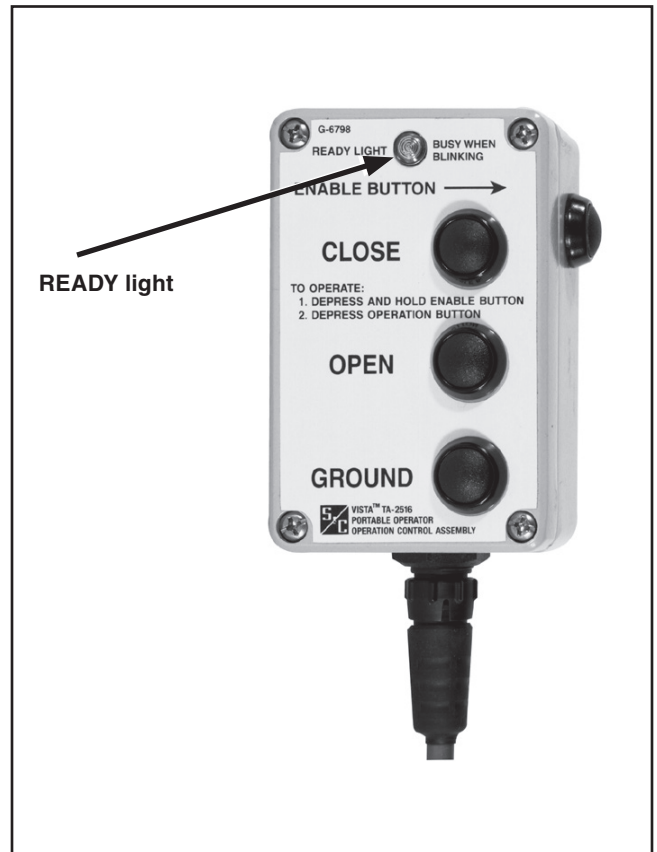

Figure 11. The READY light on the remote control.

# Operation

## Opening, Closing, or Grounding

### ⚠ WARNING

Do not operate this switchgear if the SF<sub>6</sub>-gas pressure gauge is in the red zone. Failure to follow this precaution can result in a flashover and equipment damage.

**STEP 9.** Make sure the SF<sub>6</sub>-gas pressure gauge is in the green zone (or the green and yellow striped zone) by lifting the viewing window cover under Way 1. See Figure 12.

### NOTICE

If the SF<sub>6</sub>-gas pressure gauge is in the green and yellow striped zone, the switchgear can be operated but the tank must be repaired (if necessary) and refilled with SF<sub>6</sub> gas as soon as possible.

**STEP 10.** Open the viewing window cover and confirm the position of the load-interrupter switch or the single-pole or three-pole fault-interrupter disconnect by visually observing the position of the blades. See Figures 13 and 14.

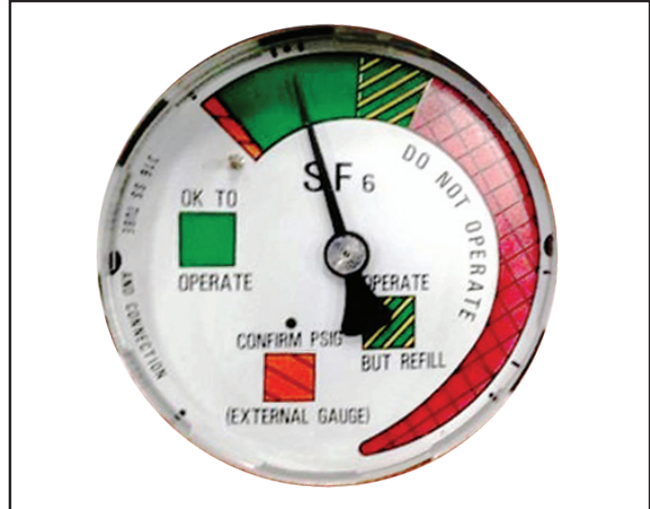

Figure 12. The SF<sub>6</sub>-gas pressure gauge.

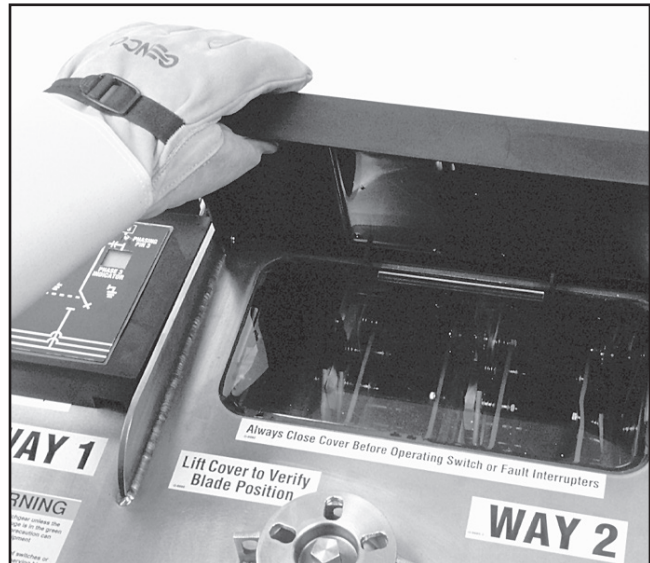

Figure 13. The window cover lifts for viewing the switch or fault-interrupter disconnect blade position.

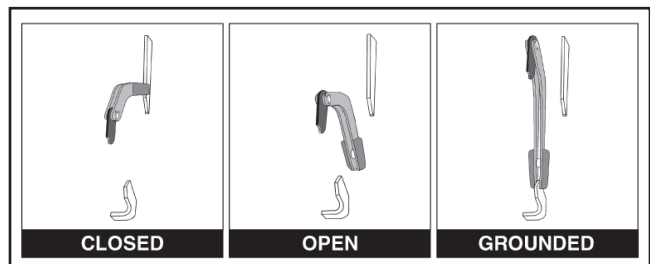

Figure 14. Confirm the blade position.



**STEP 11.**

**⚠ WARNING**

**ALWAYS** make sure the cables connected to the load-interrupter switch or fault interrupter are de-energized before grounding the switchgear. **Failure to follow this precaution can result in a flashover and equipment damage.**

To operate the portable motor operator, press and hold the ENABLE button on the remote control and press the appropriate CLOSE, OPEN, or GROUND pushbutton. See Figure 15.

**NOTICE**

The READY light on the remote control will blink while the portable operator is changing the state of the load-interrupter switch or fault interrupter. The READY light will stop blinking and light continuously only when the switching operation is complete.

If having operated a load-interrupter switch or a single-pole or three-pole fault interrupter from the **Closed** position to the **Open** position and now need to operate to the **Grounded** position, remove the portable motor operator and reposition the selector lever.

If operation is to be to the **Grounded** position, make sure the cables connected to the load-interrupter switch or single-pole or three-pole fault interrupter are de-energized. Check for voltage using the POTENTIAL indicator (option suffix “-L1” or “-L2”), if furnished, as instructed in the “Checking for Voltage Using Optional Voltage Indication” section in Instruction Sheet 681-510, 682-510, or 683-510.

If having operated a load-interrupter switch or a single-pole or three-pole fault interrupter from the **Grounded** position to the **Open** position and now wish to operate to the **Closed** position, remove the portable motor operator and reposition the selector lever.

Refer to Steps 1 through 4 for instructions on positioning the selector lever and installing the portable motor operator.

**STEP 12.** Open the viewing window cover again and confirm the position of the load-interrupter switch or single-pole or three-pole fault-interrupter disconnect by visually observing the position of the blades. See Figures 13 and 14 on page 12.



**Figure 15. The remote control ENABLE button.**



## Removal

### Removing the Portable Motor Operator

Follow these steps to remove the portable motor operator:

**STEP 13.** To remove the portable motor operator, hold the latching lever in the **Open** position and lift the portable motor operator up, off the operating shaft of the gear. See Figure 16.

#### NOTICE

The portable motor operator is not intended for permanent installation.

**STEP 14.** Before storing the portable motor operator in its carrying case, be sure to replace the caps that protect the power and remote control connectors. The caps are shown in place in Figure 16.

**STEP 15.** Replace the padlocks removed previously in Step 1.

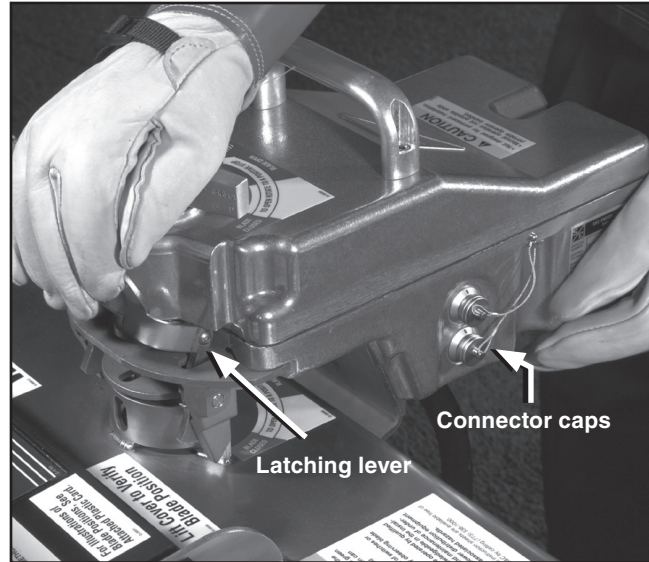

Figure 16. Removing the portable motor operator from the gear.

### If the Remote Control READY Light Does Not Light

Follow these steps if the READY light does not light:

- STEP 16.** Check to make sure the control cable is properly connected to both the portable motor operator and the remote control.
- STEP 17.** Make sure the power cable is properly connected at both the portable motor operator and the power supply ends.
- STEP 18.** If using an S&C-furnished ac-input power supply, make sure the indicator lights are lit as detailed in Step 7 on page 11. If they are not lit, verify that the ac-input power supply is connected to a properly grounded 120-Volt power source.

**NOTICE**

If the READY light blinks rapidly after the CLOSE, OPEN, or GROUND pushbutton are pressed, return the unit to S&C for repair.

**Table 1. LED Display on the S&C-Furnished Ac-Input Power Supply**

LED LABELLED	LED ON	LED FLASHES	LED OFF
DC 24 V	24 Vdc across output terminals	Overload	No output voltage – short-circuit at output – no source voltage present
LOAD 2L+	Motor operator circuit supplied with 24 Vdc		
TEMP>	Not applicable	Shutdown due to overheating	Unit temperature less than maximum allowable

### Fault Conditions on the S&C-Furnished Ac-Input Power Supply

Follow these steps if a **Fault** condition occurs on the S&C-furnished ac-input power supply:

**NOTICE**

The operating state of the ac-input power supply is indicated by LEDs on the front of the power supply, as shown in Table 1.

- STEP 19.** The S&C-furnished ac-input power supply is equipped with a **Shutdown** feature. If a short circuit develops across the 24-Volt dc output, the unit will shut itself down for at least 5 minutes. Should this occur, disconnect the power supply from the 120-Volt ac source.
- STEP 20.** Wait at least 5 minutes, and then reconnect the power supply to the 120-Volt ac source.
- STEP 21.** Verify the appropriate LEDs are lit on the front cover of the power supply, and then continue with switching operations.