

Specifications

Conditions of Sale

STANDARD: The seller's standard conditions of sale set forth in Price Sheets 150 and 153 apply, except as modified under "SPECIAL WARRANTY PROVISIONS" and "WARRANTY QUALIFICATIONS" on page 3.

SPECIAL TO THIS PRODUCT:

INCLUSIONS: S&C Vista SD Underground Distribution Switchgear features load-interrupter switches for switching 600-ampere main feeders and microprocessor-controlled fault interrupters for the switching and protection of 200- or 600-ampere taps, laterals, and sub-loops. These elbow-connected components are encapsulated in an environmentally friendly solid-dielectric insulating material. The PMH and PME configurations are available with four ways (load-interrupter switches and/or fault interrupters) in two ratings: 15 kV and 27 kV.

The PMH and PME configurations match the footprint and phase orientation of select PMH and PME pad-mounted gear models. These configurations provide a simple, straightforward solution for direct replacement of PMH and PME pad-mounted gear.

Load-Interrupter Switches

Visi-Gap® Load-Interrupter Switches use a vacuum interrupter in series with a manually operated two-position isolating disconnect for three-pole live switching of 600-ampere three-phase circuits. The switches comply with IEEE 1247, "IEEE Standard for Interrupter Switches for Alternating Current Rated Above 1000 Volts," and IEC Standard 62271-103, "High-Voltage Switches—Part 1—Switches for Rated Voltages Above 1 kV and Less Than 52 kV." They feature an easy-to-operate manual operating mechanism. Factory-installed motor operators to facilitate remote power operation of switches are optionally available (specify catalog number suffix "-B1" through "-B4").

Complete ratings for Visi-Gap Load-Interrupter Switches are shown in Table 1 on page 5. In addition to the load-dropping ratings shown, the switches are capable of interrupting transformer-magnetizing currents associated with the applicable loads as well as line-charging and cable-charging currents typical for distribution systems of these voltage ratings. For applications involving load currents with high harmonic content (such as rectifier load currents), refer to the nearest S&C Sales Office. The duty-cycle fault-closing rating shown for the switch defines

the ability to operate the switch into the **Closed** position the designated number of times against a three-phase fault equal to the rated value, with the switch remaining operable and able to carry and interrupt rated current.

Fault Interrupters

Visi-Gap® Fault Interrupters use a vacuum interrupter in series with a manually operated two-position isolating disconnect for three-pole load switching of 200- or 600- ampere circuits and fault interrupting through 16 kA symmetrical at 15 kV and through 12.5 kA symmetrical at 27 kV. The fault interrupters comply with IEEE C37.60, "IEEE Standard Requirements for Overhead, Pad-Mounted, Dry Vault, and Subsurface Automatic Circuit Reclosers and Fault Interrupters for AC Systems Up to 38 kV."

The easy-to-use manual operating mechanism for Visi-Gap Fault Interrupters is *trip-free* (the opening spring is charged when the closing spring is charged) and will open the fault interrupter automatically based on the TCC curve in the overcurrent control if the fault interrupter is inadvertently closed into a fault. Fault interruption is initiated by a programmable overcurrent control housed in a watertight enclosure. The control is programmed using a personal computer connected to the control via a USB cable (Type A to Type A). Factory-installed motor operators to facilitate remote power operation of the fault interrupters are optionally available (specify catalog number suffix "-B1" through "-B4").

Complete ratings for Visi-Gap Fault Interrupters are shown in Table 1 on page 5. In addition to the load-dropping ratings shown, the fault interrupters are capable of interrupting transformer-magnetizing currents associated with the applicable load as well as line-charging and cable-charging currents typical for distribution systems of these voltage ratings.

Manual Operation

Load-interrupter switches and fault interrupters can be directly opened and closed using the manual handle furnished; they can also be operated remotely using a piece of rope attached to the manual handle or by a user-furnished universal pole of the appropriate length equipped with a standard fitting. Opening and closing speed is not dependent on the speed with which the manual handle is moved. The operating mechanisms are designed to prevent inadvertent operation. Operating shafts are padlockable in either position.



Power Operation

Factory-installed and wired motor operators (specify catalog number suffix “-B1” through “-B4”) are optionally available to facilitate remote power operation of load-interrupter switches and fault interrupters. The motor operators can be decoupled from the operating mechanisms to permit testing without changing the positions of the switches or fault interrupters. The motor operators require a user-furnished 100–240-Vac 50/60-Hz control power source.

The motor operators are controlled by an accessory cable-connected portable remote control pendant featuring OPEN/RESET and CLOSE pushbuttons, operator- and isolating-disconnect position-indicating lamps, and a LAMP TEST button. An ENABLE pushbutton must be simultaneously pressed to prevent inadvertent operation of the load-interrupter switch or fault interrupter. When the remote control pendant is plugged into the receptacle of a factory-installed motor operator, the appropriate position-indicating lamp will light to indicate the position of the load-interrupter switch or fault interrupter. A remote-control pendant is available with either a 25-foot (762-cm) or a 50-foot (1524-cm) control cable.

Position Indication

Easy-to-follow mimic bus and indicators on the front of the switchgear assembly convey the positions of load-interrupter switches and fault interrupters (and their isolating disconnects), and whether a fault interrupter has tripped on a fault. The default color scheme is green for **Open/Reset** mode and red for **Closed** mode. To reverse these colors (i.e., green for **Closed** mode and red for **Open/Reset** mode), specify catalog number suffix “-J1.”

Auxiliary contacts furnished on ways on which motor operators have been specified track the positions of the isolating disconnect associated with each load-interrupter switch or fault interrupter. Auxiliary contacts can be optionally furnished on ways *without* motor operators to prepare the switchgear for future automation (specify catalog number suffix “-S1” through “-S4”).

Viewing Windows

Large viewing windows provide a clear view of the isolating disconnects, allowing operating personnel to easily confirm the positions of load-interrupter switches and fault interrupters.

Terminals

All load-switch terminals are equipped with 600-ampere rated bushing adapters including threaded studs; bushing adapters *without* the studs are optionally available

(specify catalog number suffix “-M1”). Fault interrupters are provided with 200-ampere bushing-well adapters and may be optionally equipped with 600-ampere bushing adapters (specify option suffix “-M3” for 600-ampere bushing adapters with studs, or option suffix “-M2” for 600-ampere bushing adapters without studs). Bushing and bushing-well adapter interfaces conform to IEEE 386, “IEEE Standard for Separable Insulated Connector Systems for Power Distribution Systems Above 600 V” and accept all standard insulated connectors and inserts.

Bushing and bushing-well adapters can be replaced *in the field* if the stud is cross-threaded during cable installation or if a subsequent termination fault damages the bushing or bushing-well adapter. Cable-centerline adapter components can also be replaced in the field in the event of a cable-termination error.

Parking stands for load-interrupter switches and fault interrupters are optionally available (specify catalog number suffix “-G1” and/or “-G2,” as required).

Cable-support brackets are provided with each switchgear assembly; these are to prevent damage to the switchgear bushings from mechanical loads developed by unsupported cables. Cable-support brackets are shipped disassembled and must be installed after the switchgear assembly has been moved into its final position.

Cable-support brackets extend below the base of pad-mounted style enclosures. Mount the switchgear assembly on a box pad, provide a cable pit, or specify a base spacer that provides a 6-inch (152-mm) or 12-inch (305 mm) increase in cable-termination height to accommodate the cable-support brackets. Cable-support brackets are not required if the switchgear assembly is to be installed on a concrete pad.

Cable-Centerline Adapters

Cable-centerline adapters reposition the termination locations so the Vista SD PMH and PME configurations more closely align with the pad-mounted gear termination points.

For PMH configurations, the cable-centerline adapters will more closely align with the cable centerlines of the PMH pad-mounted gear. This approach provides more flexibility in converting from live terminations in PMH pad-mounted gear to separable connectors.

For PME configurations, the cable-centerline adapters virtually line up to the termination interfaces of the PME pad-mounted gear, eliminating cable reconfiguration when converting from PME pad-mounted gear to Vista SD switchgear.

Potential Indication Feature

When the optional **Potential Indication** feature is specified (catalog number suffix “-L2”), routine switching can be accomplished by a single person without cable handling or exposure to medium voltage. The **Potential Indication** feature includes provisions for low-voltage phasing. Cable-testing can be performed through the back of a user-furnished 600-ampere dead-break connector or 200-ampere feed-thru device, eliminating the need for difficult cable handling.

Vista Overcurrent Control 2.0

The overcurrent control can be programmed using a personal computer. Current transformers provide power and input signals. The control features a variety of time-current characteristic (TCC) curves—standard “E,” “K,” and “T” speed curves, Vista coordinating-speed tap and main curves, and relay curves per IEEE C37.112-1996. Minimum trip current settings as low as 14 amperes are available.

Coordinating-speed tap curves are used for fault interrupters feeding subloop taps and are specifically designed to optimize coordination with load-side weak-link/backup current-limiting fuse combinations and source-side relays with low time-dial settings. The coordinating-speed main curves are used for fault interrupters on main feeders and have a longer minimum response time and a different shape to coordinate with tap-interrupter curves.

Coordinating speed tap and main curves, as well as relay curves per IEEE C37.112-1996, can also be tailored to the application using a variety of definite-time settings. Ground-protection, negative-sequence, and sensitive-earth fault settings are also available.

Pad-Mount Enclosure

Vista SD Underground Distribution Switchgear for PMH and PME configurations are pad-mounted, furnished with a mild-steel or stainless steel pad-mounted-style enclosure, and contain controls and switchgear that are fully submersible. These enclosures meet the requirements of IEEE C57.12.28, “IEEE Standard for Pad-Mounted Equipment Enclosure Integrity,” and C57.12.29, “IEEE Standard for Pad-Mounted Equipment Enclosure Integrity for Coastal Environments.”

A resilient closed-cell gasket on the enclosure bottom flange protects the finish from being scratched during installation and isolates it from the alkalinity of a concrete foundation. All enclosures are protected from corrosion by S&C’s Ultradur® II Outdoor Finish; the standard color is olive green, but other colors are optionally available.

EXCLUSIONS: The units listed in Table 2 on pages 6 and 7 do not include optional features or accessories listed in Tables 4 and 6 on pages 8 through 10.

SPECIAL WARRANTY PROVISIONS: The standard warranty contained in the seller’s standard conditions of sale, as set forth in Price Sheets 150 and 181, applies only to manual Vista SD Underground Distribution Switchgear and its associated options. The Vista Overcurrent Control 2.0 shall have the following warranty provisions; the first and second paragraphs of Price Sheet 150 warranty are replaced with the following:

(1) General: The seller warrants to the immediate purchaser or end user for a period of 10 years from the date of shipment that the equipment delivered will be of the kind and quality specified in the contract description and will be free of defects of workmanship and material. Should any failure to conform to this warranty appear under proper and normal use within 10 years after the date of shipment, the seller agrees, upon prompt notification thereof and confirmation that the equipment has been stored, installed, operated, and maintained in accordance with recommendations of the seller and standard industry practice, to correct the nonconformity either by repairing any damaged or defective parts of the equipment or (at the seller’s option) by shipment of necessary replacement parts. The seller’s warranty does not apply to any equipment that has been disassembled, repaired, or altered by anyone other than the seller. This limited warranty is granted only to the immediate purchaser or, if the equipment is purchased by a third party for installation in third-party equipment, the end user of the equipment. The seller’s duty to perform under any warranty may be delayed, at the seller’s sole option, until the seller has been paid in full for all goods purchased by the immediate purchaser. No such delay shall extend the warranty period.

The seller further warrants to the immediate purchaser or end user that for a period of two years from the date of shipment the software will perform substantially in accordance with the then-current release of specifications if properly used in accordance with the procedures described in the seller’s instructions. The seller’s liability regarding any of the software is expressly limited to exercising its reasonable efforts in supplying or replacing any media found to be physically defective or in correcting defects in the software during the warranty period. The seller does not warrant the use of the software will be uninterrupted or error-free.

WARRANTY QUALIFICATIONS: The seller’s standard warranty does not apply to components not of S&C manufacture that are supplied and installed by the purchaser or to the ability of seller’s equipment to work with such components.

Anatomy of a PMH and PME Vista SD Switchgear Catalog Number:

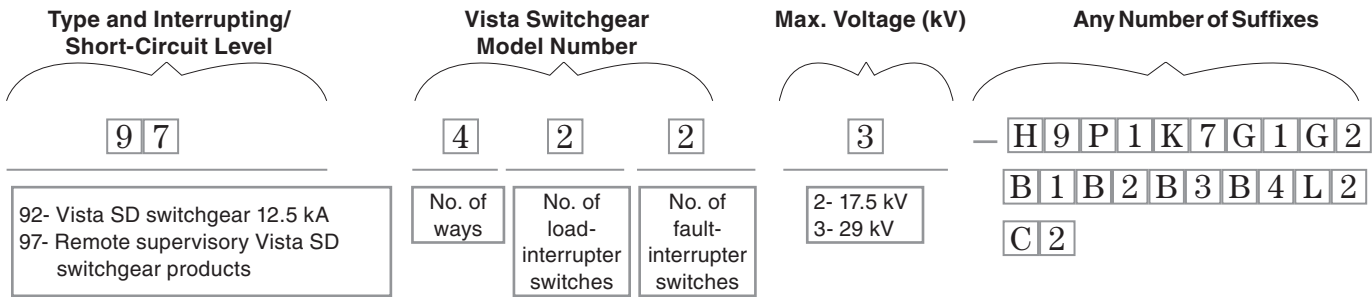

Note: The catalog number created above represents a remote supervisory Vista SD switchgear unit in a pad-mounted style designed to fit an existing PMH-9 footprint, 12.5 kA, for a 29-kV application. The enclosure will be mild steel with the standard olive green finish. The unit will have a 6-inch (152-mm) base spacer, parking stands for all ways, motor operators on all ways, potential indication, and cable-center line adapters to more closely align with a PMH pad-mounted gear.

How to Order

Complete these steps to identify the base catalog number, the appropriate options, and the product accessories needed for a complete order:

STEP 1. Obtain the catalog number of the desired switchgear unit from Table 2 on pages 6 and 7.

Note: If the unit will include a low-voltage enclosure for a remote supervisory or source-transfer application, use “97” for the first two digits of this portion of the catalog number.

Catalog Number:

STEP 2. Specify the desired switchgear enclosure from Table 3 on page 7 and add the appropriate suffix to the catalog number.

Suffix:

STEP 3. Add suffix designations to the catalog number indicating the optional features desired, selected from Table 4 on pages 8 and 9. (Add as many suffixes as required.)

Suffixes:

Note: At this point, the catalog number for the PMH and PME Vista SD switchgear unit is com-

plete. The next steps, using Tables 6 and 7 on page 10, are for product accessories and touch-up kit components and would be separate line items on the order. Contact S&C for additional available options.

STEP 4. Obtain catalog numbers for any accessories from Table 6 on page 10 and apply as a separate line item on the order.

Catalog Number:

STEP 5. Include touch-up kit components from Table 7 on page 10.

Catalog Number:

Example: The catalog number for a manual Vista SD switchgear unit in a pad-mounted style designed to fit an existing PME-11 footprint, 12.5 kA, for a 17.5-kV application is noted below. The enclosure will be stainless steel with a light gray finish. The unit will also have cable-centerline adapters to more closely align with a PME pad-mounted gear.

9 2 4 3 1 2 — E 1 1 P 1 1 A 2 C 1

Table 1. 50/60-Hz IEEE Ratings (IEC Ratings in Parentheses)

Voltage, kV			Amperes, RMS						
System Class	Max	BIL	Main Bus		Visi-Gap Load-Interrupter Switch			Visi-Gap Fault Interrupter	
			Continuous Current	Short-Circuit, RMS, Sym.	Cont., Load Dropping, and Load Splitting ^①	Mom. and Three-Second, Sym.	Three-Time, Duty-Cycle Fault Closing, Sym. ^②	Cont., Load Dropping, and Load Splitting ^{①③}	Short Circuit Interrupting
15 (12)	17.5 (17.5)	95 (75)	600 (630)	16 000	600 (630)	16 000	16 000	200 (200)	12 500●
27 (24)	29 (29)	125 (125)	600 (630)	12 500	600 (630)	12 500	12 500	200 (200)	12 500

① Parallel or loop switching. Load-interrupter switches and fault interrupters can switch the magnetizing current of transformers associated with this rating. Unloaded cable switching capability: 10 amperes at 15 kV, 20 amperes at 27 kV. Load-interrupter switches and fault interrupters can also switch single capacitor banks through 1800 kvar.

② Applicable to fault closing into closed position.

③ 600 amperes if fault interrupters are furnished with optional 600-ampere bushing wells.

● 16 000 amperes if fault interrupters are furnished with optional 600-ampere bushings.

Table 2. Vista SD Switchgear—PMH and PME Configurations

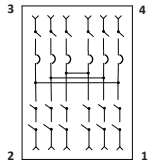
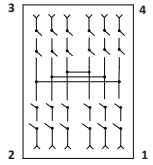
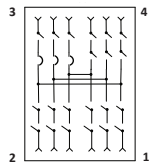
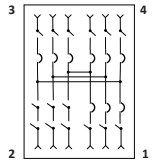
Model ^①	Replacement For	Connection Diagram	Ratings (IEEE rating)					Catalog Number
			Voltage		Amperes, RMS Sym.			
			kV, Max	BIL	Load Switch	Fault Interrupter	Main Bus	
422	PMH 9		17.5 (17.5)	95 (75)	16 000 (16 000)	12 500● (12 500)	16 000 (16 000)	924222-H9
			29 (29)	125 (125)	12 500 (12 500)	12 500 (12 500)	12 500 (12 500)	924223-H9
440	PMH 10		17.5 (17.5)	95 (75)	16 000 (16 000)	12 500● (12 500)	16 000 (16 000)	924402-H10
			29 (29)	125 (125)	12 500 (12 500)	12 500 (12 500)	12 500 (12 500)	924403-H10
431	PMH 11		17.5 (17.5)	95 (75)	16 000 (16 000)	12 500● (12 500)	16 000 (16 000)	924312-H11
			29 (29)	125 (125)	12 500 (12 500)	12 500 (12 500)	12 500 (12 500)	924313-H11
413	PMH 12		17.5 (17.5)	95 (75)	16 000 (16 000)	12 500● (12 500)	16 000 (16 000)	924132-H12
			29 (29)	125 (125)	12 500 (12 500)	12 500 (12 500)	12 500 (12 500)	924133-H12

① Model number defines the total number of ways, the number of load-interrupter switch ways, and the number of fault-interrupter ways. For example, Model 422 has “4” ways in total, “2” load-interrupter switch ways and “2” fault-interrupter ways.

● Fault interrupter ways supplied with 600-ampere bushings (option “-M2” or “-M3”) have a fault-interrupting rating of 16 000 A symmetrical.

TABLE CONTINUED ►

Table 2. Vista SD Switchgear—PMH and PME Configurations—Continued

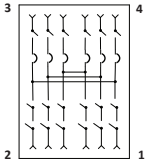
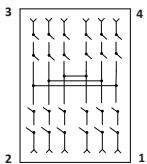
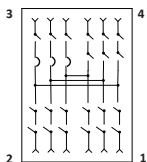
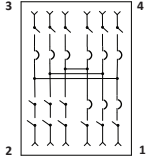
Model ^①	Replacement For	Connection Diagram	Ratings (IEEE rating)					Catalog Number
			Voltage		Amperes, RMS, Sym.			
			kV, Max	BIL	Load Switch	Fault Interrupter	Main Bus	
422	PME 9		17.5 (17.5)	95 (75)	16 000 (16 000)	12 500● (12 500)	16 000 (16 000)	924222-E9
			29 (29)	125 (125)	12 500 (12 500)	12 500 (12 500)	12 500 (12 500)	924223-E9
440	PME 10		17.5 (17.5)	95 (75)	16 000 (16 000)	12 500● (12 500)	16 000 (16 000)	924402-E10
			29 (29)	125 (125)	12 500 (12 500)	12 500 (12 500)	12 500 (12 500)	924403-E10
431	PME 11		17.5 (17.5)	95 (75)	16 000 (16 000)	12 500● (12 500)	16 000 (16 000)	924312-E11
			29 (29)	125 (125)	12 500 (12 500)	12 500 (12 500)	12 500 (12 500)	924313-E11
413	PME 12		17.5 (17.5)	95 (75)	16 000 (16 000)	12 500● (12 500)	16 000 (16 000)	924132-E12
			29 (29)	125 (125)	12 500 (12 500)	12 500 (12 500)	12 500 (12 500)	924133-E12

① Model number defines the total number of ways, the number of load-interrupter switch ways, and the number of fault-interrupter ways. For example, Model 422 has “4” ways in total, “2” load-interrupter switch ways and “2” fault-interrupter ways.

● Fault interrupter ways supplied with 600-ampere bushings (option “-M2” or “-M3”) have a fault-interrupting rating of 16 000 A symmetrical.

Table 3. Switchgear Enclosure—Must Be Specified

Item	Suffix to be Added to Switchgear Catalog Number	Applicable to Models
Mild steel enclosure	P1	All
Stainless steel enclosure	P11	All

Vista® SD Underground Distribution Switchgear

Table 4. Optional Features

Item	Suffix to be Added to Switchgear Catalog Number		Applicable to Models	
Alternate-color outdoor finish	Light gray	A2	All	
	Equipment green	A3		
	Seafoam green	A4		
	Special color	A5		
Cable-centerline adapters. Additional buswork to move cable termination location to approximately match bushing and bushing well height, as well as cable centerlines, of associated PME Pad-Mounted Gear model		C1	All PME configuration models	
Cable-centerline adapters. Additional buswork to more closely align with the cable centerlines of associated PMH Pad-Mounted Gear model		C2	All PMH configuration models	
Base spacer, increases cable termination height	Mild Steel	6 inches (152 mm)	K7	All
		12 inches (305 mm)	K8	
	Stainless Steel	6 inches (152 mm)	K17	
		12 inches (305 mm)	K18	
Mounting provisions for fault indicator for each load-interrupter switch. Accommodates three-phase indicator with single-phase sensors	No viewing window in door	F1	All	
	Viewing window in door	F2		
Parking stands	At all load-interrupter switches	G1	All	
	At all fault interrupters	G2	413, 422, 431	
Reverse color of the OPEN/RESET and CLOSED indicators (i.e., green for Closed and red for Open/Reset)		J1	All	
Potential indication. Indicates presence of voltage on each phase. One indicator is provided for each load-interrupter switch and fault interrupter way. Includes provisions for low-voltage phasing		L2	All	
600-ampere bushing adapters without studs on all load-interrupter switches (in lieu of 600-ampere bushing adapters with studs)		M1	All	
600-ampere bushings at fault-interrupter terminals (in lieu of 200-A bushing wells) ①	Without studs	M2	413, 422, 431	
	With studs	M3		
Hexhead bolt in lieu of pentahead bolt		N	All	
Continuous ground bus. Connects to all load-interrupter switches and fault interrupters; provides convenient location to attach cable concentric neutrals, separable connector drain wires, and user-provided grounding cables. Short-circuit rating of ground bus equals that of the switchgear assembly		O	All	
Motor operator. Permits remote operation of load-interrupter switch or fault interrupter. Includes receptacle for wired portable motor operator, plus auxiliary contacts to track position of isolating disconnect. Requires user-furnished 120-240-Vac, 50/60-Hz control power source	Way 1	B1	All	
	Way 2	B2	All	
	Way 3	B3	All	
	Way 4	B4	All	
Auxiliary contacts for way not furnished with motor operator. Track position of the isolating disconnect associated with each load-interrupter switch or fault interrupter	Way 1	S1	All	
	Way 2	S2	All	
	Way 3	S3	All	
	Way 4	S4	All	
Compartment shelves		U	All	
Key interlocks to prevent paralleling of switches in Ways 1 and 2		W1	422, 431, 440	
Key interlocks to prevent opening fault interrupter compartment doors unless all switches are locked open		W3	422	
Key interlocks. Combines functions of options “-W1” and “-W3” above		W4	422	
Key interlock. Locks load-interrupter switch or fault interrupter in open position	Way 1	X1	All	
	Way 2	X2	All	
	Way 3	X3	All	
	Way 4	X4	All	

① For the “-M2” or “-M3” option, cable centerlines move towards the Ways by 5/8 inches (137 mm) for configurations without cable-centerline adapters.

TABLE CONTINUED ►

Table 4. Optional Features—Continued

Item	Suffix to be Added to Switchgear Catalog Number		Applicable to Models
External trip provisions. Allow tripping of fault interrupters using trip signal from remote location or external relay. Requires user-furnished 110–120-Vac, 50/60-Hz control power source	In addition to standard overcurrent control for all fault interrupters	R31	413, 422, 431
	In lieu of standard control and current transformers for all fault interrupters	R41	
External trip provisions. Allow tripping of fault interrupters using trip signal from remote location or external relay. Requires user-furnished 220–240-Vac, 50/60-Hz control power source	In addition to standard overcurrent control for all fault interrupters	R33	413, 422, 431
	In lieu of standard control and current transformers for all fault interrupters	R43	
Alternate-language Labels	Spanish	L51	All
	Portuguese	L52	
	French	L53	
	Chinese	L54	
	Arabic	L55	
International crating. Wood products used in packaging are hardwood or certified by supplier to be “heat-treated” (kiln-dried) to a core temperature of 133°F (56°C) for a minimum of 30 minutes		L71	All

Table 5. Replacement Parts

Item	Catalog Number
600-ampere bushing adapter kit	CHA-1976
200-ampere bushing-well adapter kit	CHA-1975
Tool for removing/installing bushing and bushing-well adapters①	CH-2728

① Tool can be used to remove/install 600-ampere bushing adapters; must be used to remove/install 200-ampere bushing-well adapters.

Vista® SD Underground Distribution Switchgear

Table 6. Accessories

Item		Catalog Number
Shotgun clamp stick—for use with separable connectors	6-foot-5½-inch (197-cm) length	9933-150
	8-foot-½-inch (245-cm) length	9933-151
Storage bag for shotgun clamp stick. Heavy canvas	6-foot-6-inch (198-cm) length	9933-152
	8-foot-6-inch (259-cm) length	9933-153
Pentahead socket for ½-inch drive		9931-074
Motor operator.①② Facilitates power operation of load-interrupter switches or fault interrupters. Can be permanently attached to load-interrupter switches or fault interrupters or can be used as a portable motor operator to effect operation of a load-interrupter switch or fault interrupter from a remote location. Requires user-furnished 120–240-Vac, 50/60-Hz control power source. Motor operator is fully submersible		38415-A
Portable remote control pendant with 25-foot (762-cm) cable.③ Includes OPEN/RESET, CLOSE, and ENABLE pushbuttons, operator- and isolating-disconnect position-indicating lamps, and LAMP TEST button. Pendant is fully submersible		TA-3273-25
Portable remote control pendant with 50-foot (1524-cm) cable.③ Includes OPEN/RESET, CLOSE, and ENABLE pushbuttons, operator- and isolating-disconnect position-indicating lamps, and LAMP TEST button. Pendant is fully submersible		TA-3273-50

① Order portable remote control pendant, one per switchgear assembly or one for each portable motor operator.

② If switchgear is furnished with optional auxiliary contacts (catalog number suffix “-S1” through “-S6”), portable remote control pendant will show position of load-interrupter switch or fault interrupter and position of isolating disconnect.

③ Default color scheme for operator and isolating-disconnect position-indicating lamps is green for “Open/Reset” and red for “Closed.” To reverse these colors, (i.e., green for “Closed” and red for “Open/Reset”), specify catalog number suffix “-J1.”

Table 7. Touch-Up Kit Components—Aerosol Coatings in 9-Ounce Cans

Item	Catalog Number
S&C light gray outdoor finish	9999-080
S&C olive green outdoor finish	9999-058
S&C seafoam green outdoor finish	9991363-493
S&C equipment green outdoor finish	9991363-488
S&C red-oxide primer	9999-061

Vista SD Underground Distribution Switchgear
PMH Configurations with Cable-Centerline Adapters

Dimensions in inches (mm)

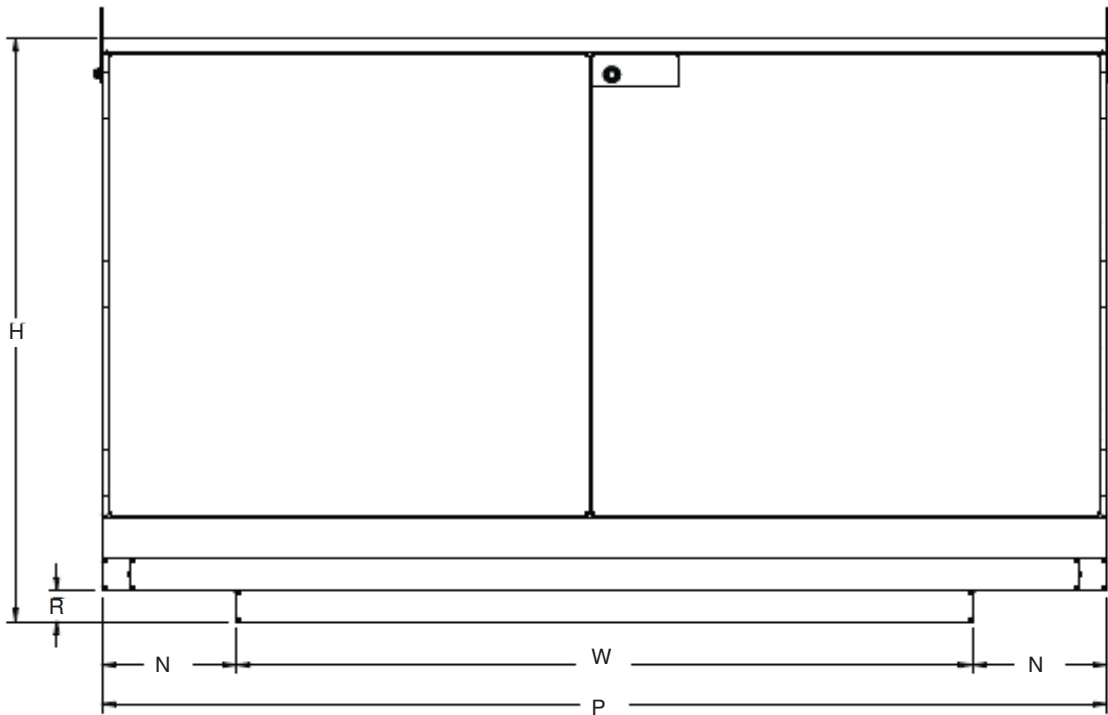

FRONT VIEW

Table 8. Front View Dimensions

Vista SD Model	PMH Replacement	Voltage, kV (IEC rating)	H	N	P	R	W
422	PMH 9	15 (12)	56 (1422)	12¼ (311)	91½ (2324)	3 (76)	67 (1702)
		27 (24)	60 (1524)	4¾ (121)		6⅞ (175)	82 (2083)
440	PMH 10	15 (12)	56 (1422)	12¼ (311)	91½ (2324)	3 (76)	67 (1702)
		27 (24)	60 (1524)	4¾ (121)		6⅞ (175)	82 (2083)
431	PMH 11	15 (12)	56 (1422)	12¼ (311)	91½ (2324)	3 (76)	67 (1702)
		27 (24)	60 (1524)	4¾ (121)		6⅞ (175)	82 (2083)
413	PMH 12	15 (12)	56 (1422)	12¼ (311)	91½ (2324)	3 (76)	67 (1702)
		27 (24)	60 (1524)	4¾ (121)		6⅞ (175)	82 (2083)

Vista® SD Underground Distribution Switchgear

Vista SD Underground Distribution Switchgear PMH Configurations with Cable-Centerline Adapters

Dimensions in inches (mm)

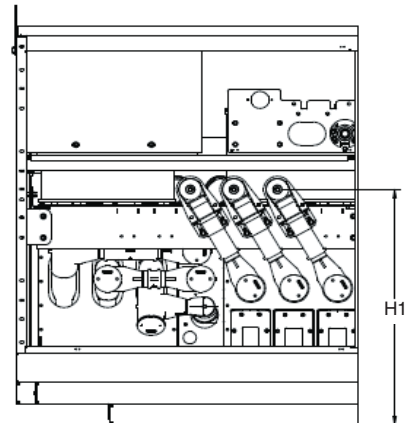
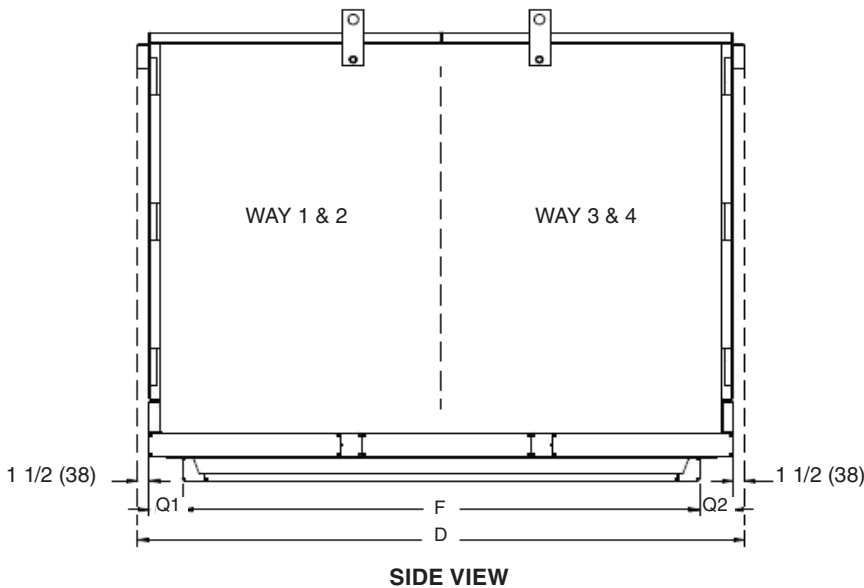

**TYPICAL CABLE INTERFACE VIEW
FOR SWITCHES WITH CABLE
CENTERLINE ADAPTERS**

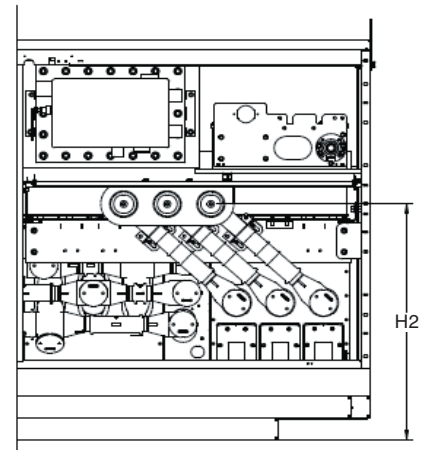

**TYPICAL CABLE INTERFACE VIEW
FOR FAULT INTERRUPTERS WITH
CABLE CENTERLINE ADAPTERS**

Table 9. Side and Cable Interface Dimensions

Vista SD Model	PMH Replacement	Voltage, kV (IEC rating)	D	F	H1	H2	Q1	Q2
422	PMH 9	15 (12)	71½ (1816)	60¾ (1543)	33 (838)	33 (838)	3⅞ (98)	3⅞ (98)
		27 (24)	84¾ (2153)	76¾ (1949)	34¼ (870)	38¾ (984)	3⅝ (92)	1⅞ (35)
440	PMH 10	15 (12)	71½ (1816)	60¾ (1543)	33 (838)	—	3⅞ (98)	3⅞ (98)
		27 (24)	80½ (2045)	76¾ (1949)	34¼ (870)	—	¾ (10)	¾ (10)
431	PMH 11	15 (12)	71½ (1816)	60¾ (1543)	33 (838)	33 (838)	3⅞ (98)	3⅞ (98)
		27 (24)	84¾ (2153)	76¾ (1949)	34¼ (870)	38¾ (984)	3⅝ (92)	1⅞ (35)
413	PMH 12	15 (12)	71½ (1816)	60¾ (1543)	33 (838)	33 (838)	3⅞ (98)	3⅞ (98)
		27 (24)	84¾ (2153)	76¾ (1949)	34¼ (870)	38¾ (984)	1⅞ (35)	3⅝ (92)

Vista SD Underground Distribution Switchgear
PMH Configurations with Cable-Centerline Adapters

Dimensions in inches (mm)

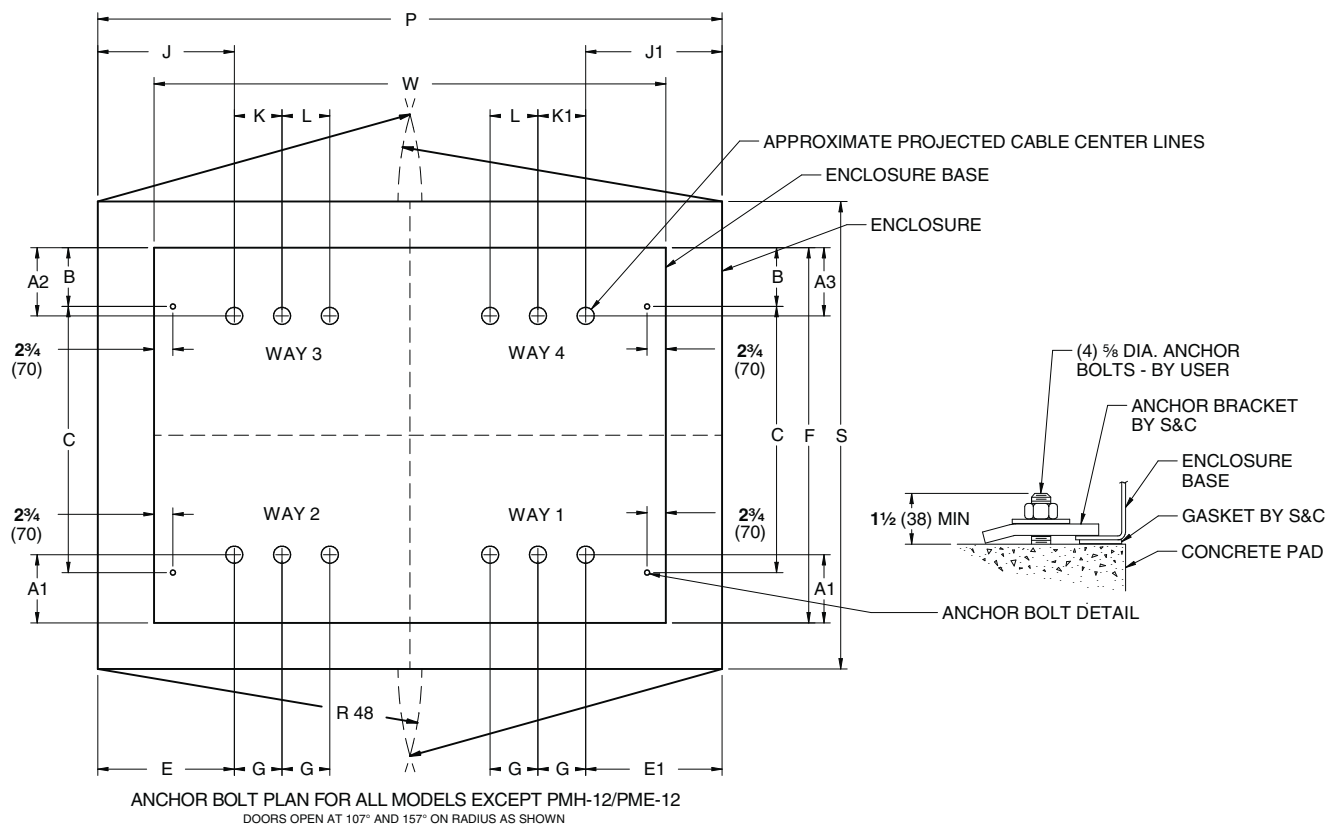

Table 10. Anchor Bolt Plan Dimensions for Models 422, 440 and 431

Vista SD Model	PMH Replacement	Voltage, kV (IEC rating)	A1	A2	A3	B	C	E	E1	F	G
422	PMH 9	15 (12)	9 ⁷ / ₈ (251)	6 ³ / ₄ (171)	6 ³ / ₄ (171)	5 ¹ / ₈ (130)	40 (1016)	22 ⁷ / ₈ (581)	22 ⁷ / ₈ (581)	60 ³ / ₄ (1543)	5 ³ / ₄ (146)
		27 (24)	14 ¹ / ₈ (359)	12 (305)	12 (305)	7 ¹ / ₈ (181)	62 ¹ / ₂ (1588)	19 ⁹ / ₈ (492)	19 ⁹ / ₈ (492)	76 ³ / ₄ (1949)	
440	PMH 10	15 (12)	9 ³ / ₄ (248)	9 ³ / ₄ (248)	9 ³ / ₄ (248)	15 ⁵ / ₈ (397)	29 ¹ / ₂ (749)	22 ⁷ / ₈ (581)	22 ⁷ / ₈ (581)	60 ³ / ₄ (1543)	5 ³ / ₄ (146)
		27 (24)	15 ¹ / ₈ (384)	15 ³ / ₈ (391)	15 ³ / ₈ (391)	7 ¹ / ₈ (181)	62 ¹ / ₂ (1588)	19 ⁹ / ₈ (492)	19 ⁹ / ₈ (492)	76 ³ / ₄ (1949)	
431	PMH 11	15 (12)	9 ¹ / ₂ (241)	7 ¹ / ₄ (184)	9 ¹ / ₂ (241)	15 ⁵ / ₈ (397)	29 ¹ / ₂ (749)	22 ⁷ / ₈ (581)	22 ⁷ / ₈ (581)	60 ³ / ₄ (1543)	5 ³ / ₄ (146)
		27 (24)	14 ¹ / ₈ (359)	12 (305)	13 ³ / ₈ (340)	7 ¹ / ₈ (181)	62 ¹ / ₂ (1588)	19 ⁹ / ₈ (492)	19 ⁹ / ₈ (492)	76 ³ / ₄ (1949)	

TABLE CONTINUED ►

Vista SD Underground Distribution Switchgear PMH Configurations with Cable-Centerline Adapters

Dimensions in inches (mm)

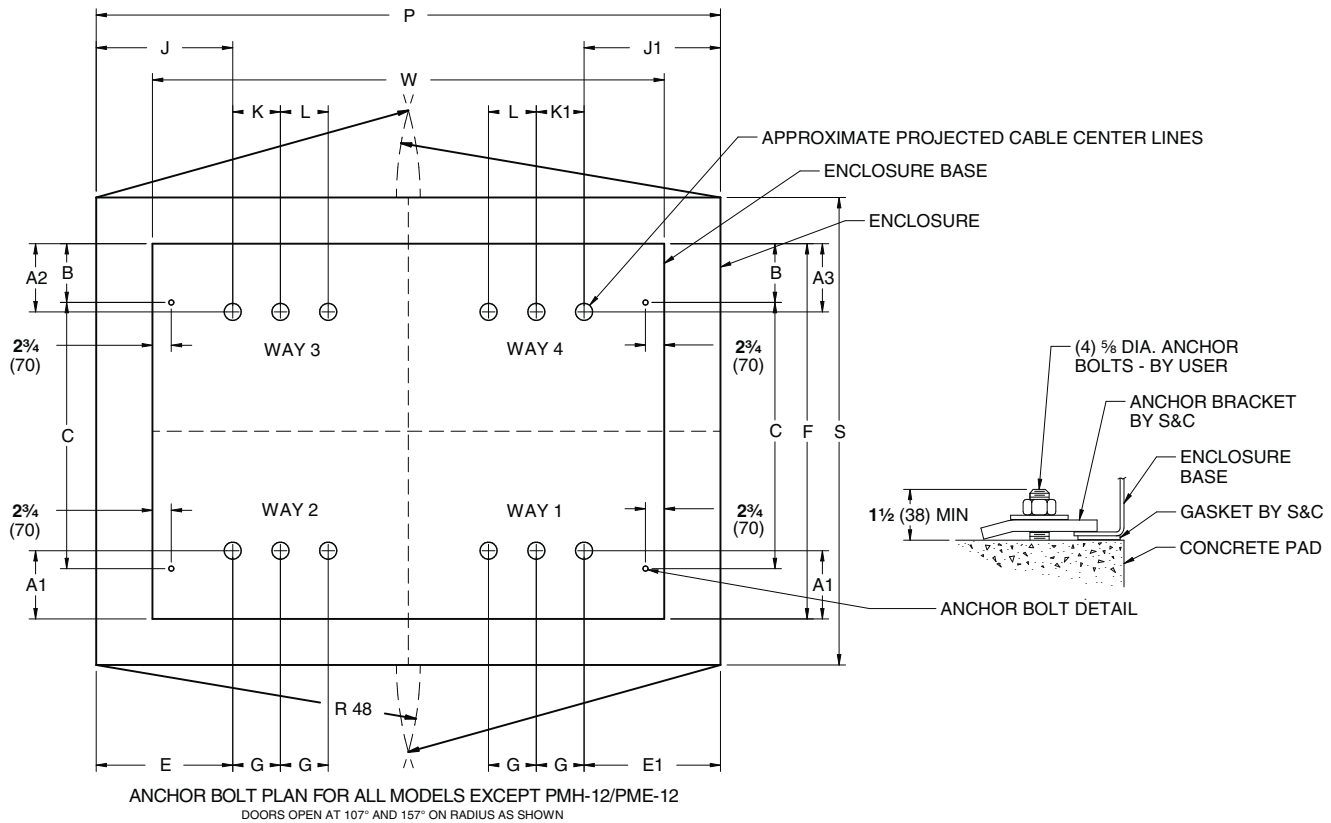

Table 10. Anchor Bolt Plan Dimensions for Models 422, 440 and 431—Continued

Vista SD Model	PMH Replacement	Voltage, kV (IEC rating)	J	J1	K	K1	L	P	S	W
422	PMH 9	15 (12)	21 ¹ / ₈ (537)	21 ¹ / ₈ (537)	5 ³ / ₄ (146)	5 ³ / ₄ (146)	5 ³ / ₄ (146)	91 ¹ / ₂ (2324)	68 ¹ / ₂ (1740)	67 (1702)
		27 (24)	19 ¹ / ₄ (489)	19 ¹ / ₄ (489)					81 ³ / ₄ (2076)	82 (2083)
440	PMH 10	15 (12)	26 ¹ / ₄ (667)	26 ¹ / ₄ (667)	5 ³ / ₄ (146)	5 ³ / ₄ (146)	5 ³ / ₄ (146)	91 ¹ / ₂ (2324)	68 ¹ / ₂ (1740)	67 (1702)
		27 (24)	17 ⁷ / ₈ (448)	17 ⁷ / ₈ (448)			11 ⁷ / ₈ (289)		77 ¹ / ₂ (1969)	82 (2083)
431	PMH 11	15 (12)	21 ¹ / ₈ (537)	26 ¹ / ₄ (667)	5 ³ / ₄ (146)	5 ³ / ₄ (146)	5 ³ / ₄ (146)	91 ¹ / ₂ (2324)	68 ¹ / ₂ (1740)	67 (1702)
		27 (24)	19 ¹ / ₄ (489)	17 ⁷ / ₈ (448)					81 ³ / ₄ (2076)	82 (2083)

Vista SD Underground Distribution Switchgear
PMH Configurations with Cable-Centerline Adapters

Dimensions in inches (mm)

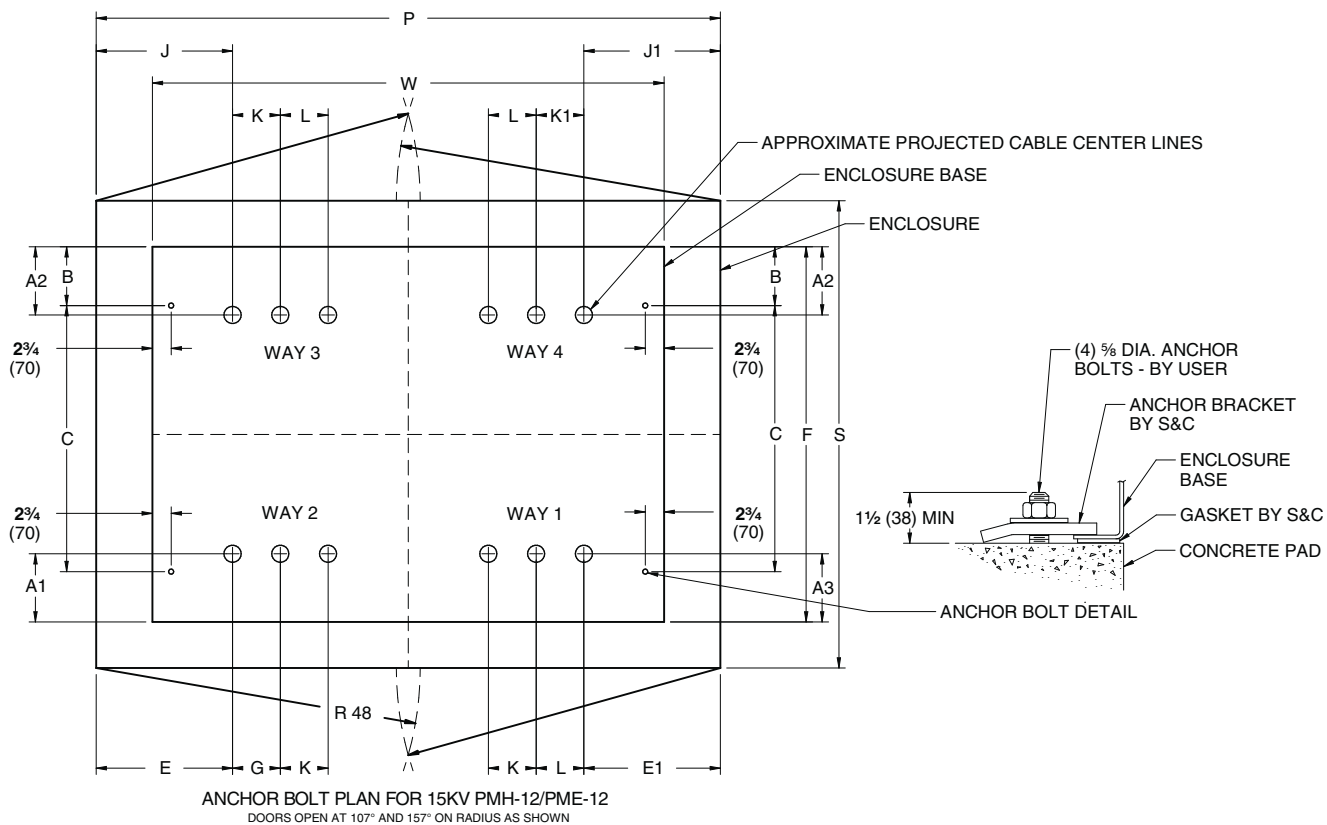

Table 11. Anchor Bolt Plan Dimensions for Model 413 at 15 kV

Vista SD Model	PMH Replacement	Voltage, kV (IEC rating)	A1	A2	A3	B	C	E	E1	F	G
413	PMH 12	15 (12)	9 7/8 (251)	6 3/4 (171)	7 1/2 (191)	5 1/8 (130)	40 (1016)	26 1/8 (664)	21 1/8 (537)	60 3/4 (1543)	5 3/4 (146)

TABLE CONTINUED ►

Vista SD Underground Distribution Switchgear PMH Configurations with Cable-Centerline Adapters

Dimensions in inches (mm)

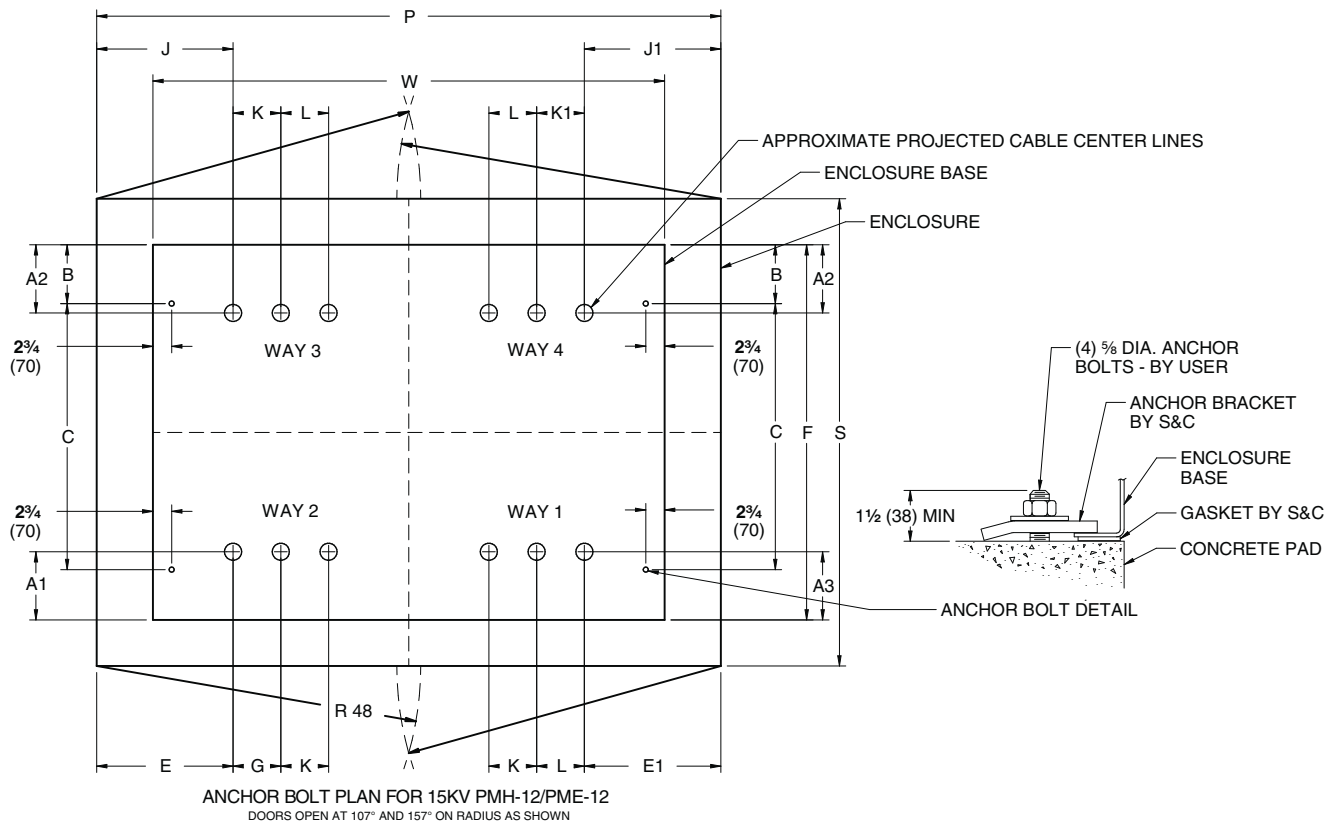

Table 11. Anchor Bolt Plan Dimensions for Model 413 at 15 kV—Continued

Vista SD Model	PMH Replacement	Voltage, kV (IEC rating)	J	J1	K	K1	L	P	S	W
413	PMH 12	15 (12)	22 ⁷ / ₈ (581)	22 ⁷ / ₈ (581)	5 ³ / ₄ (146)	5 ³ / ₄ (146)	5 ³ / ₄ (146)	91 ¹ / ₂ (2324)	68 ¹ / ₂ (1740)	67 (1702)

Vista SD Underground Distribution Switchgear
PMH Configurations with Cable-Centerline Adapters

Dimensions in inches (mm)

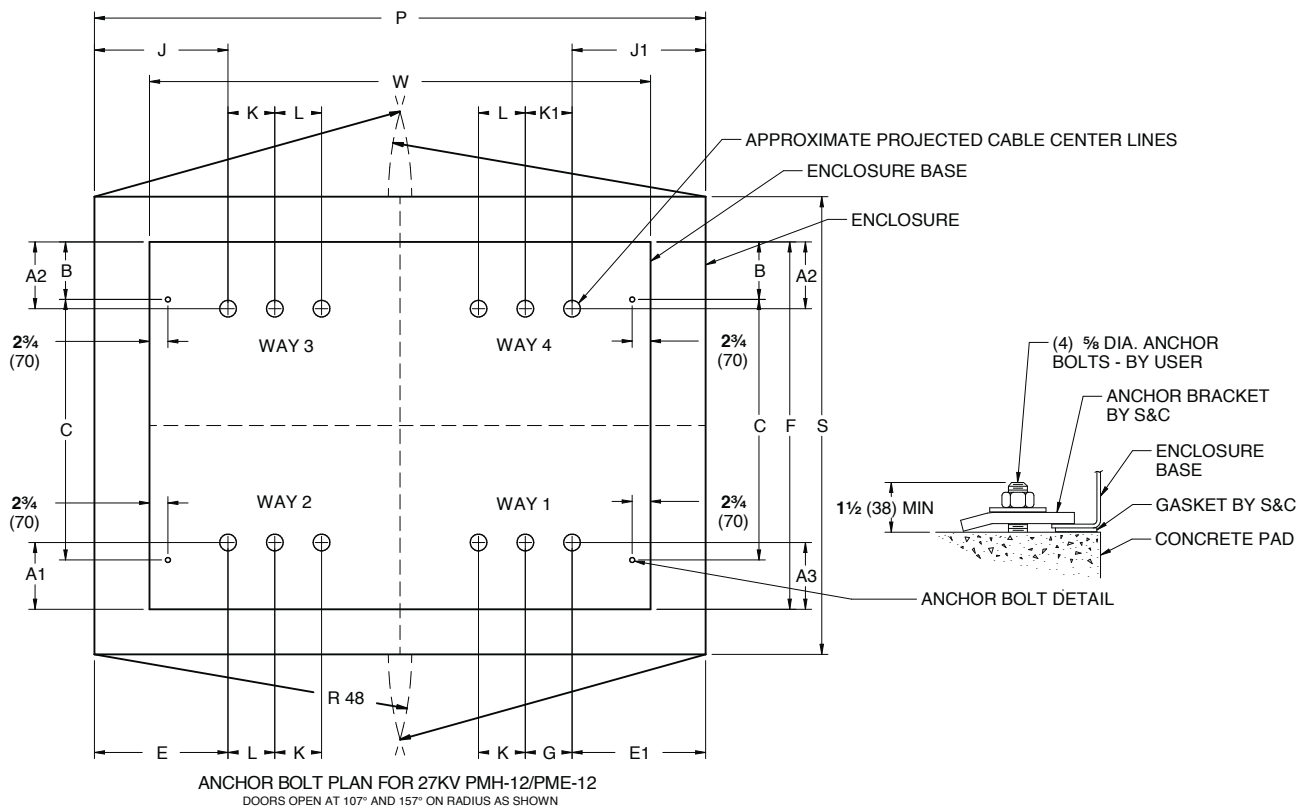

Table 12. Anchor Bolt Plan Dimensions for Model 413 at 27 kV

Vista SD Switchgear Model	PMH Replacement	Voltage, kV (IEC rating)	A1	A2	A3	B	C	E	E1	F	G
413	PMH 12	27 (24)	17 ³ / ₄ (451)	13 ³ / ₈ (340)	15 (381)	7 ¹ / ₈ (181)	62 ¹ / ₂ (1588)	17 ³ / ₈ (448)	19 ¹ / ₄ (489)	76 ³ / ₄ (1949)	5 ³ / ₄ (146)

TABLE CONTINUED ►

Vista SD Underground Distribution Switchgear PMH Configurations with Cable-Centerline Adapters

Dimensions in inches (mm)

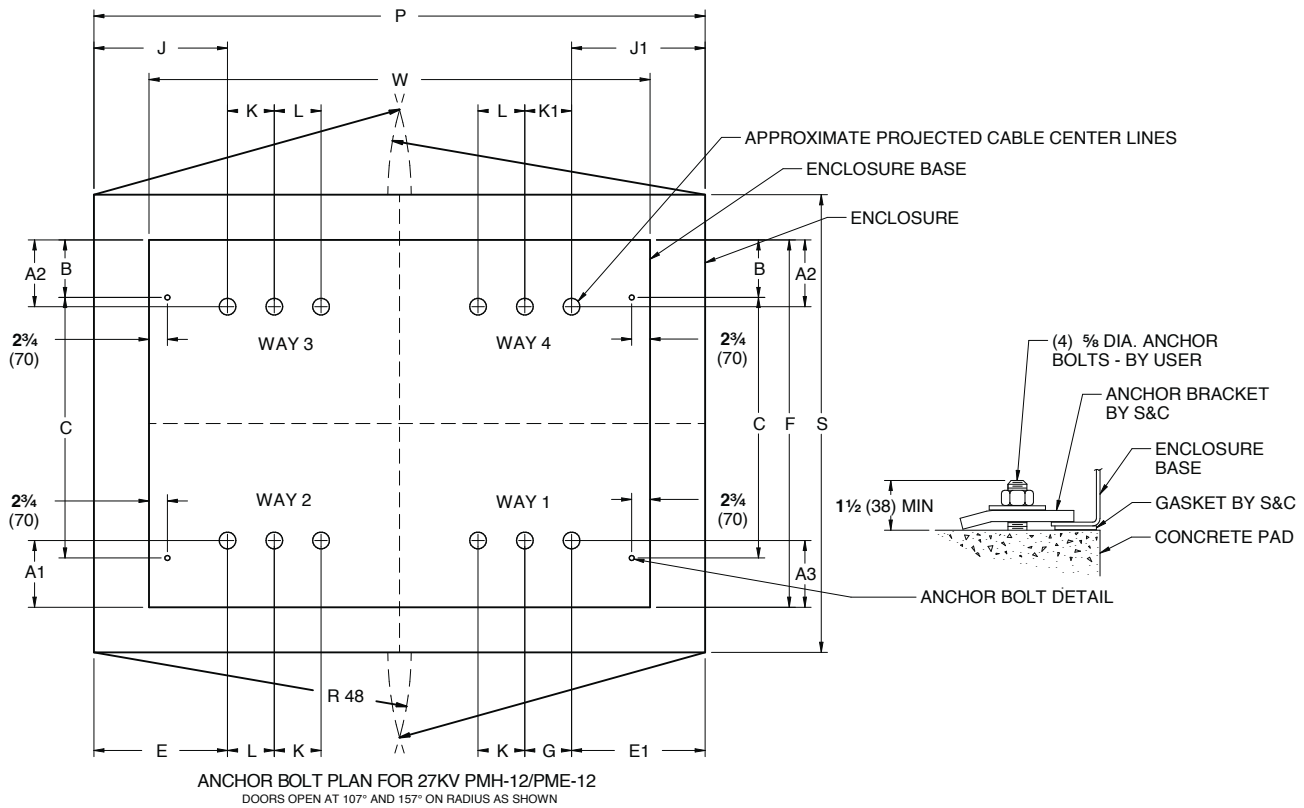

Table 12. Anchor Bolt Plan Dimensions for Model 413 at 27 kV—Continued

Vista SD Switchgear Model	PMH Replacement	Voltage, kV (IEC rating)	J	J1	K	K1	L	P	S	W
413	PMH 12	27 (24)	17 ³ / ₄ (451)	17 ³ / ₄ (451)	5 ³ / ₄ (146)	5 ³ / ₄ (146)	5 ³ / ₄ (146)	91 ¹ / ₂ (2324)	81 ³ / ₄ (2076)	82 (2083)

Vista SD Underground Distribution Switchgear
 PMH Configurations without Cable-Centerline Adapters

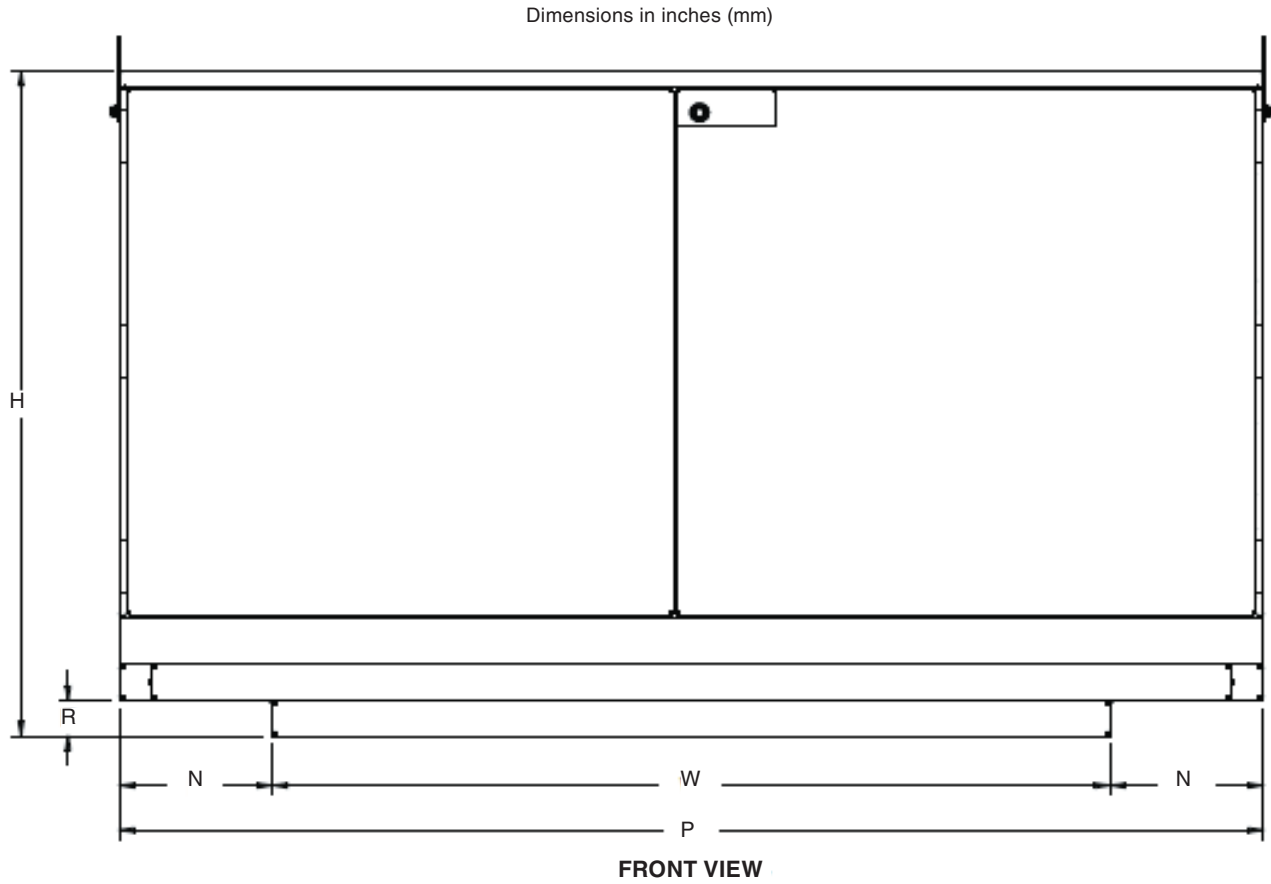

Table 13. Front Dimensions

Vista SD Switchgear Model	PMH Replacement	Voltage, kV (IEC rating)	H	N	P	R	W
422	PMH 9	15 (12)	56 (1422)	12 ¹ / ₄ (311)	9 ¹ / ₂ (2324)	3 (76)	67 (1702)
		27 (24)	60 (1524)	4 ³ / ₄ (121)		6 ⁷ / ₈ (175)	82 (2083)
440	PMH 10	15 (12)	56 (1422)	12 ¹ / ₄ (311)	9 ¹ / ₂ (2324)	3 (76)	67 (1702)
		27 (24)	60 (1524)	4 ³ / ₄ (121)		6 ⁷ / ₈ (175)	82 (2083)
431	PMH 11	15 (12)	56 (1422)	12 ¹ / ₄ (311)	9 ¹ / ₂ (2324)	3 (76)	67 (1702)
		27 (24)	60 (1524)	4 ³ / ₄ (121)		6 ⁷ / ₈ (175)	82 (2083)
413	PMH 12	15 (12)	56 (1422)	12 ¹ / ₄ (311)	9 ¹ / ₂ (2324)	3 (76)	67 (1702)
		27 (24)	60 (1524)	4 ³ / ₄ (121)		6 ⁷ / ₈ (175)	82 (2083)

Vista® SD Underground Distribution Switchgear

Vista SD Underground Distribution Switchgear PMH Configurations without Cable-Centerline Adapters

Dimensions in inches (mm)

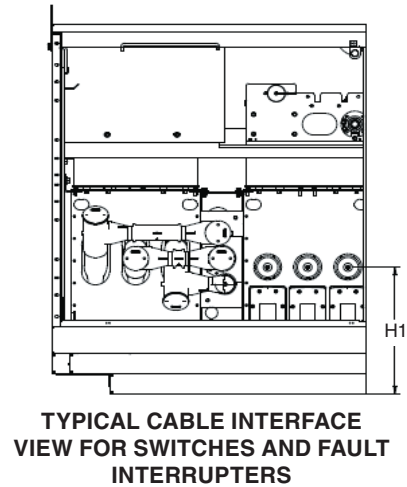
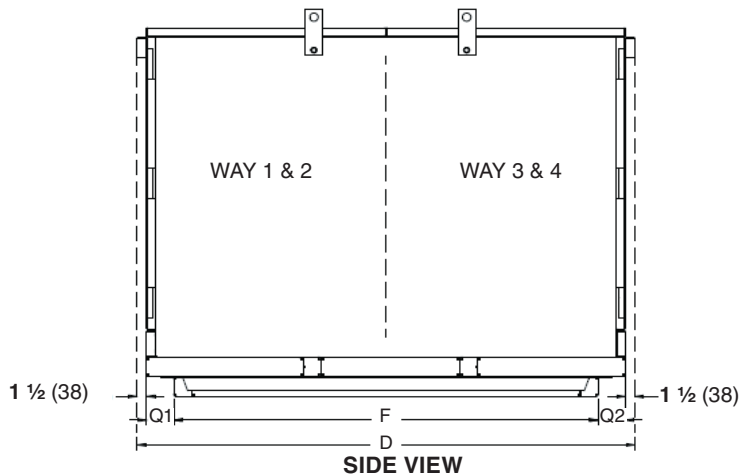

Table 14. Side and Cable Interface Dimensions

Vista SD Switchgear Model	PMH Replacement	Voltage, kV (IEC rating)	D	F	H1	Q1	Q2
422	PMH 9	15 (12)	71½ (1816)	60¾ (1543)	19¼ (489)	3⅞ (98)	3⅞ (98)
		27 (24)	84¾ (2153)	76¾ (1949)	23 (584)	3⅝ (92)	1⅝ (35)
440	PMH 10	15 (12)	71½ (1816)	60¾ (1543)	19¼ (489)	3⅞ (98)	3⅞ (98)
		27 (24)	80½ (2045)	76¾ (1949)	23 (584)	⅝ (10)	⅝ (10)
431	PMH 11	15 (12)	71½ (1816)	60¾ (1543)	19¼ (489)	3⅞ (98)	3⅞ (98)
		27 (24)	84¾ (2153)	76¾ (1949)	23 (584)	3⅝ (92)	1⅝ (35)
413	PMH 12	15 (12)	71½ (1816)	60¾ (1543)	19¼ (489)	3⅞ (98)	3⅞ (98)
		27 (24)	84¾ (2153)	76¾ (1949)	23 (584)	1⅝ (35)	3⅝ (92)

Vista SD Underground Distribution Switchgear
PMH Configurations without Cable-Centerline Adapters

Dimensions in inches (mm)

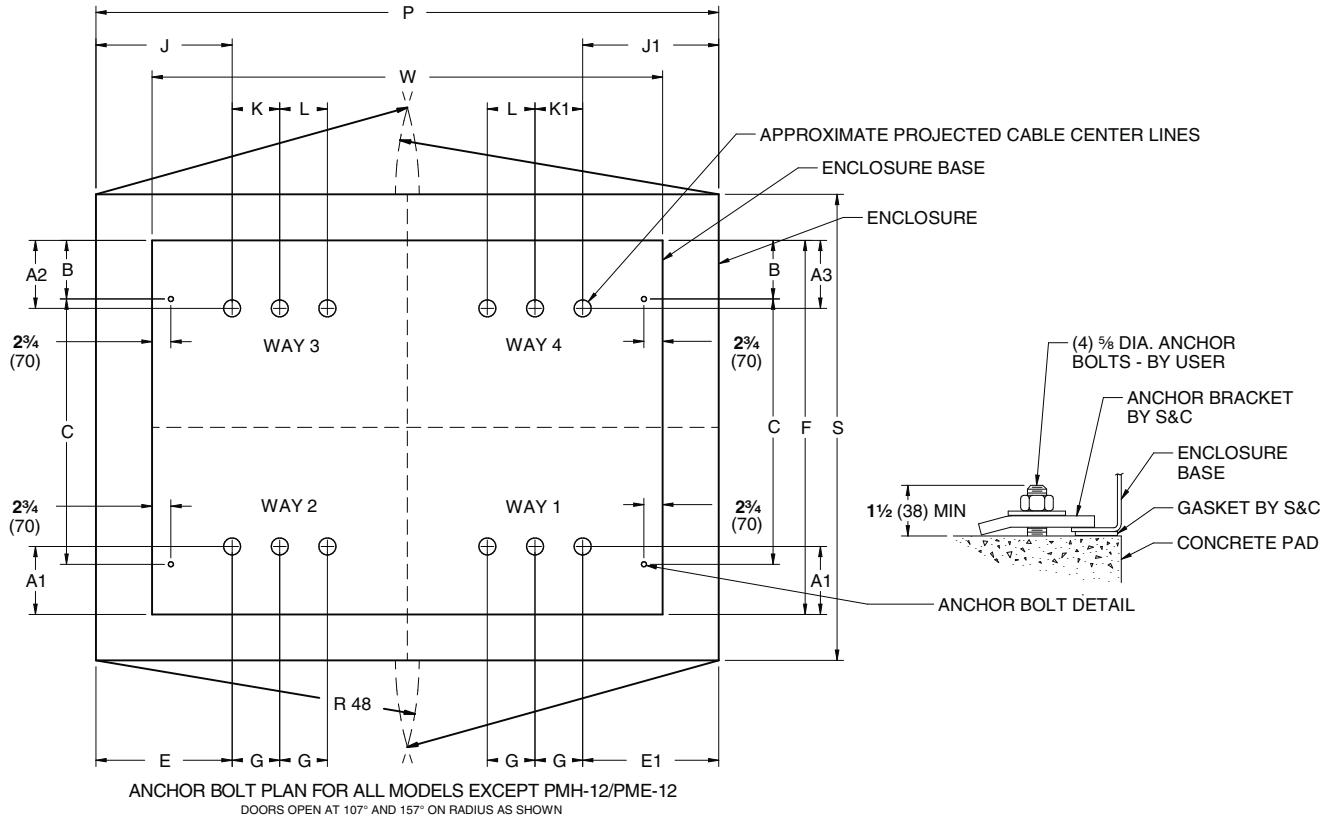

Table 15. Anchor Bolt Plan Dimensions for Models 422, 440 and 431

Vista SD Switchgear Model	PMH Replacement	Voltage, kV (IEC rating)	A1	A2	A3	B	C	E	E1	F	G
422	PMH 9	15 (12)	11 ⁷ / ₈ (302)	7 (178)	7 (178)	5 ¹ / ₈ (130)	40 (1016)	30 ⁷ / ₈ (784)	30 ⁷ / ₈ (784)	60 ³ / ₄ (1543)	5 ³ / ₄ (146)
		27 (24)	16 ¹ / ₈ (410)	12 ¹ / ₈ (308)	12 ¹ / ₈ (308)	7 ¹ / ₈ (181)	62 ¹ / ₂ (1588)	30 ³ / ₄ (781)	30 ³ / ₄ (781)	76 ³ / ₄ (1949)	
440	PMH 10	15 (12)	11 ³ / ₄ (298)	11 ³ / ₄ (298)	11 ³ / ₄ (298)	15 ⁵ / ₈ (397)	29 ¹ / ₂ (749)	30 ³ / ₄ (781)	30 ³ / ₄ (781)	60 ³ / ₄ (1543)	5 ³ / ₄ (146)
		27 (24)	17 ¹ / ₈ (435)	17 ³ / ₈ (441)	17 ³ / ₈ (441)	7 ¹ / ₈ (181)	62 ¹ / ₂ (1588)			76 ³ / ₄ (1949)	
431	PMH 11	15 (12)	11 ¹ / ₂ (292)	7 ¹ / ₂ (191)	11 ¹ / ₂ (292)	15 ⁵ / ₈ (397)	29 ¹ / ₂ (749)	30 ³ / ₄ (781)	30 ³ / ₄ (781)	60 ³ / ₄ (1543)	5 ³ / ₄ (146)
		27 (24)	16 ¹ / ₈ (410)	12 ³ / ₈ (314)	19 ⁷ / ₈ (505)	7 ¹ / ₈ (181)	62 ¹ / ₂ (1588)			76 ³ / ₄ (1949)	

TABLE CONTINUED ►

Vista® SD Underground Distribution Switchgear

Vista SD Underground Distribution Switchgear PMH Configurations without Cable-Centerline Adapters

Dimensions in inches (mm)

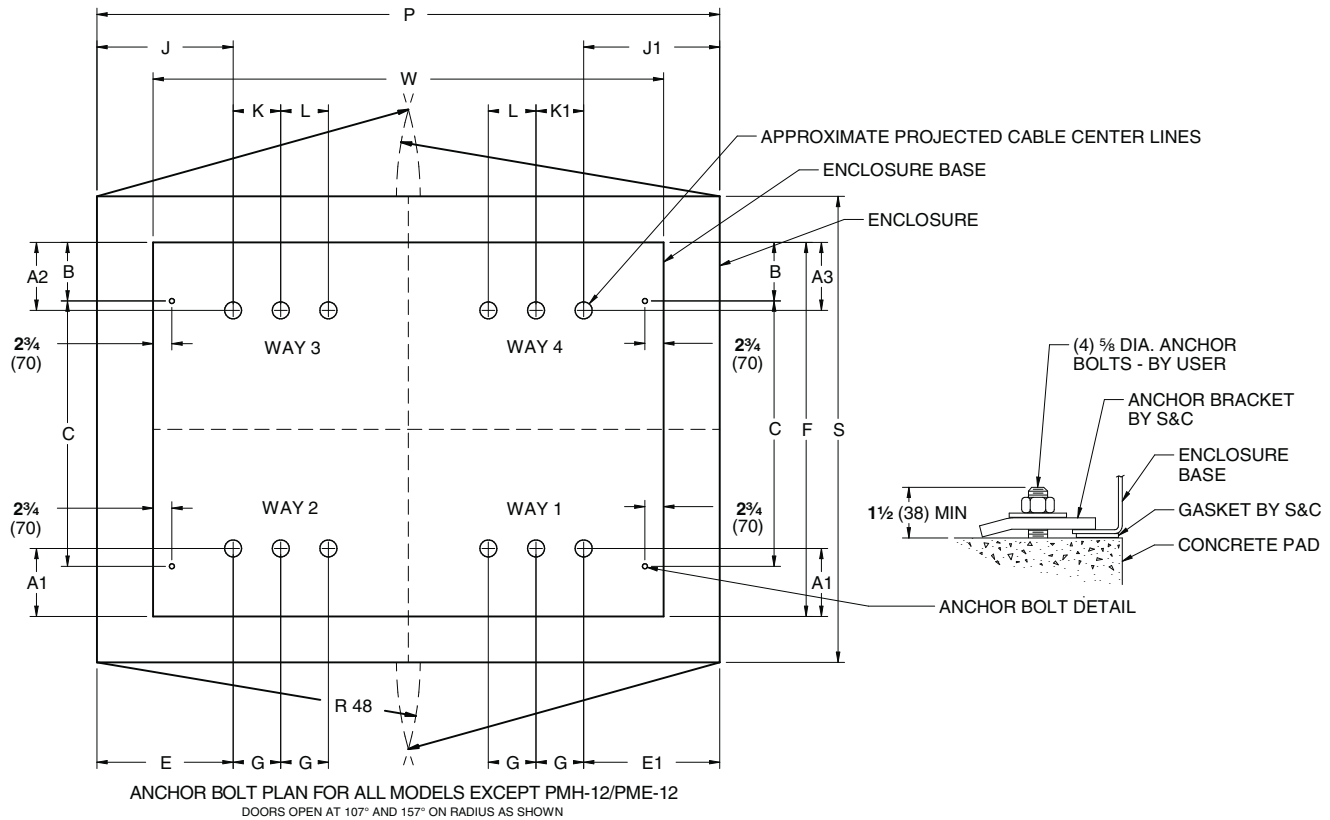

Table 15. Anchor Bolt Plan Dimensions for Models 422, 440 and 431—Continued

Vista SD Switchgear Model	PMH Replacement	Voltage, kV (IEC rating)	J	J1	K	K1	L	P	S	W
422	PMH 9	15 (12)	6 ¹ / ₈	6 ¹ / ₈	5 ³ / ₄	5 ³ / ₄	5 ³ / ₄	91 ¹ / ₂	68 ¹ / ₂	67
		27 (24)	(156)	(156)	(146)	(146)	(146)	(2324)	81 ³ / ₄	82
440	PMH 10	15 (12)	6 ¹ / ₈	6 ¹ / ₈	5 ³ / ₄	5 ³ / ₄	5 ³ / ₄	91 ¹ / ₂	68 ¹ / ₂	67
		27 (24)	(156)	(156)	(146)	(146)	(146)	(2324)	77 ¹ / ₂	82
431	PMH 11	15 (12)	6 ¹ / ₈	6 ¹ / ₈	5 ³ / ₄	5 ³ / ₄	5 ³ / ₄	91 ¹ / ₂	68 ¹ / ₂	67
		27 (24)	(156)	(156)	(146)	(146)	(146)	(2324)	81 ³ / ₄	82

Vista SD Underground Distribution Switchgear
PMH Configurations without Cable-Centerline Adapters

Dimensions in inches (mm)

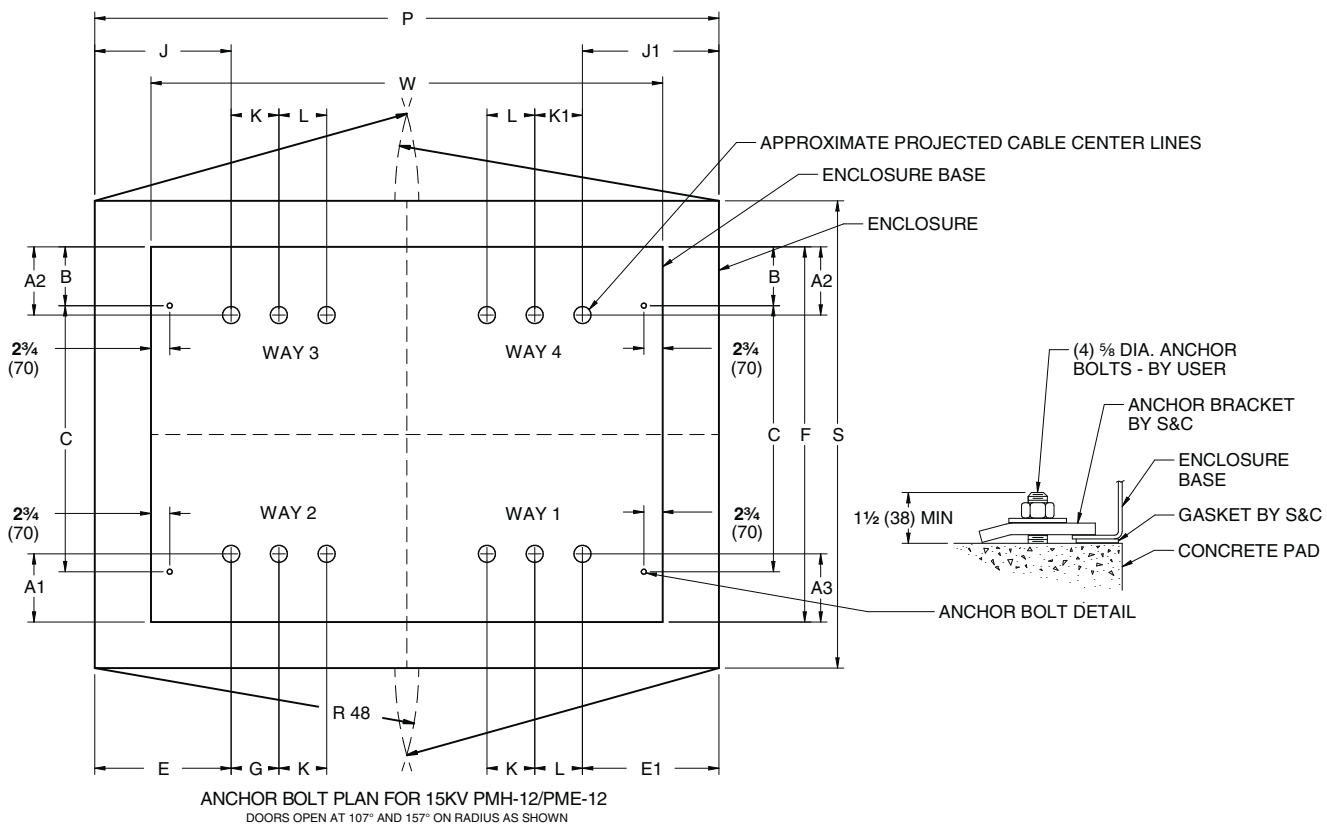

Table 16. Anchor Bolt Plan Dimensions for Model 413 at 15 kV

Vista SD Switchgear Model	PMH Replacement	Voltage, kV (IEC rating)	A1	A2	A3	B	C	E	E1	F	G
413	PMH 12	15 (12)	11 ⁷ / ₈ (302)	7 (178)	7 ⁷ / ₈ (200)	5 ¹ / ₈ (130)	40 (1016)	6 ¹ / ₈ (156)	6 ¹ / ₈ (156)	60 ³ / ₄ (1543)	5 ³ / ₄ (146)

TABLE CONTINUED ►

Vista® SD Underground Distribution Switchgear

Vista SD Underground Distribution Switchgear PMH Configurations without Cable-Centerline Adapters

Dimensions in inches (mm)

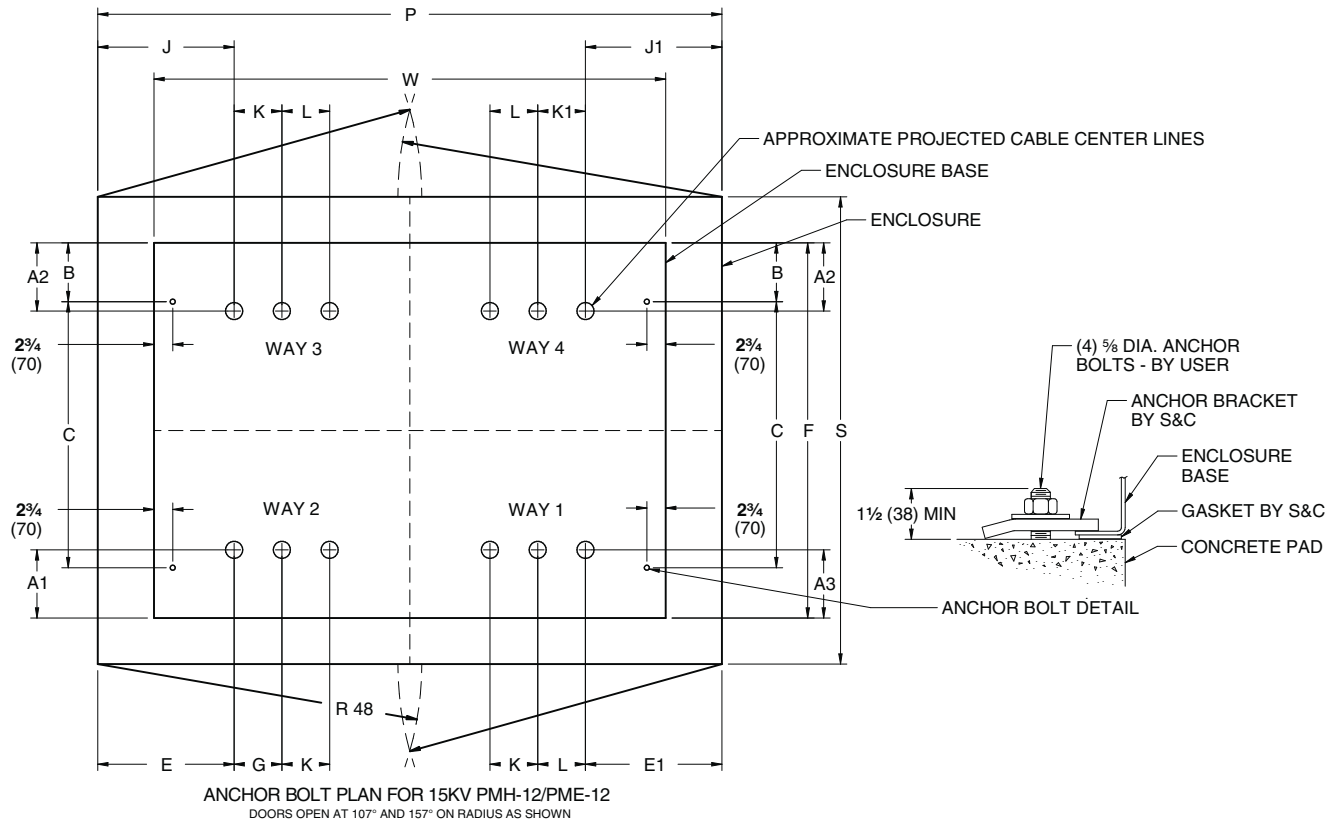

Table 16. Anchor Bolt Plan Dimensions for Model 413 at 15 kV—Continued

Vista SD Switchgear Model	PMH Replacement	Voltage, kV (IEC rating)	J	J1	K	K1	L	P	S	W
413	PMH 12	15 (12)	30¾ (781)	30¾ (781)	5¾ (146)	5¾ (146)	5¾ (146)	91½ (2324)	68½ (1740)	67 (1702)

Vista SD Underground Distribution Switchgear
PMH Configurations without Cable-Centerline Adapters

Dimensions in inches (mm)

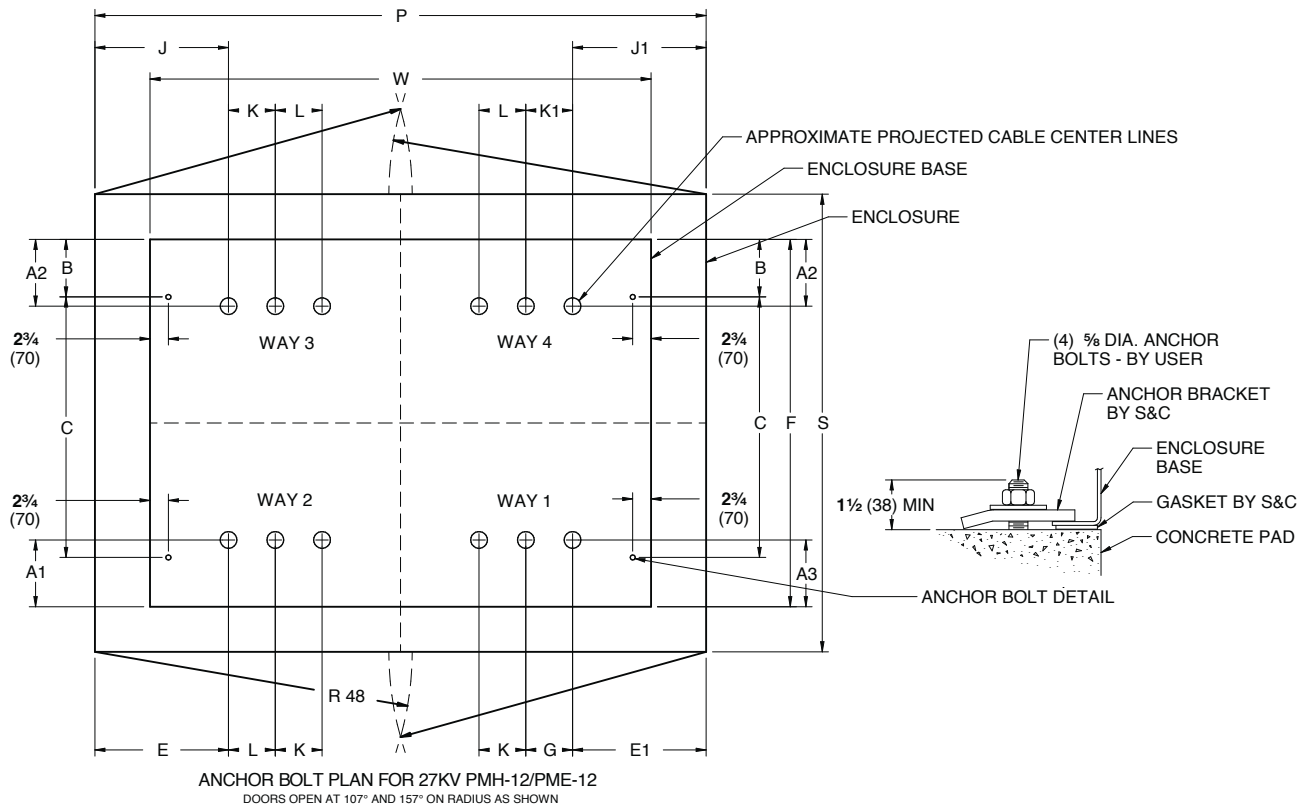

Table 17. Anchor Bolt Plan Dimensions for Model 413 at 27 kV

Vista SD Model	PMH Replacement	Voltage, kV (IEC rating)	A1	A2	A3	B	C	E	E1	F	G
413	PMH 12	27 (24)	19 ³ / ₄ (502)	13 ³ / ₈ (346)	15 ¹ / ₄ (387)	7 ¹ / ₈ (181)	62 ¹ / ₂ (1588)	6 ¹ / ₈ (156)	6 ¹ / ₈ (156)	76 ³ / ₄ (1949)	5 ³ / ₄ (146)

TABLE CONTINUED ►

Vista® SD Underground Distribution Switchgear

Vista SD Underground Distribution Switchgear PMH Configurations without Cable-Centerline Adapters

Dimensions in inches (mm)

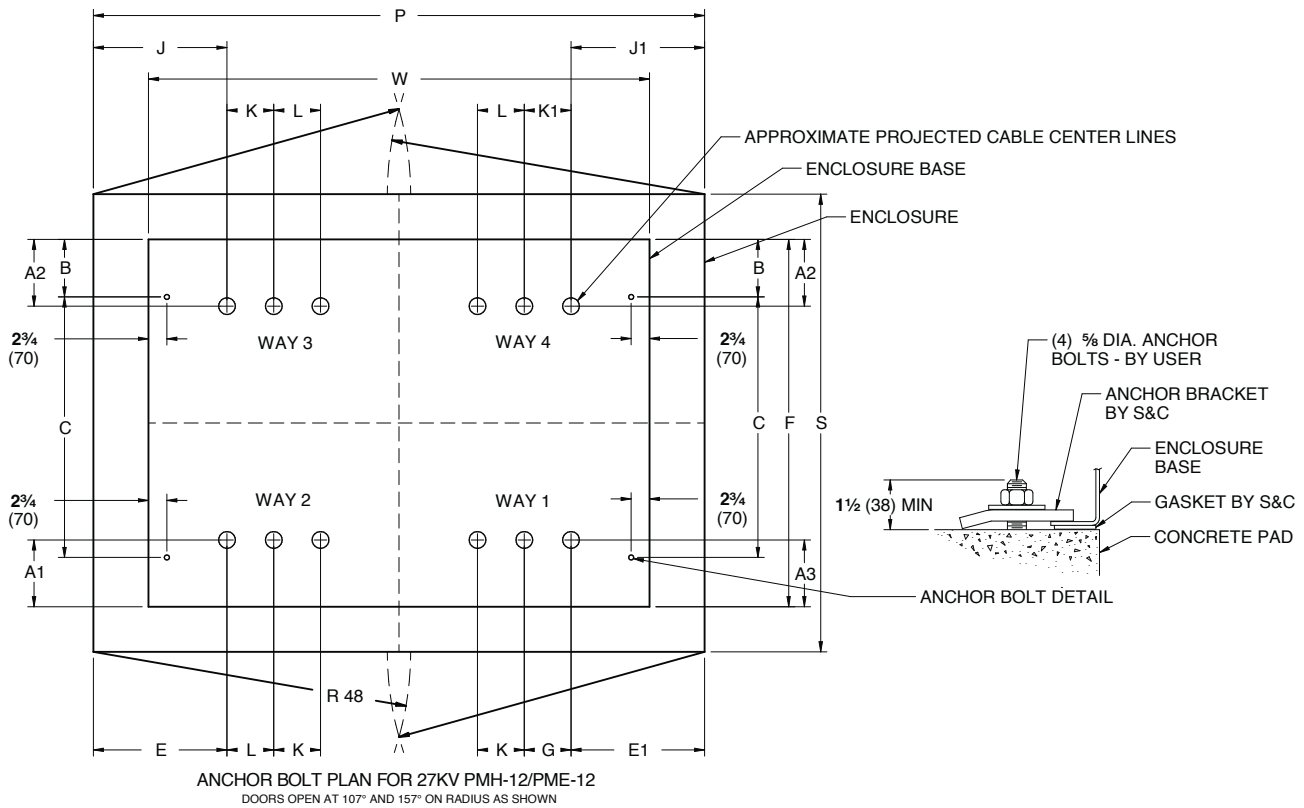

Table 17. Anchor Bolt Plan Dimensions for Model 413 at 27 kV—Continued

Vista SD Switchgear Model	PMH Replacement	Voltage, kV (IEC rating)	J	J1	K	K1	L	P	S	W
413	PMH 12	27 (24)	30¾ (781)	30¾ (781)	5¾ (146)	5¾ (146)	5¾ (146)	91½ (2324)	81¾ (2076)	82 (2083)

Vista SD Underground Distribution Switchgear
PME Configurations with Cable-Centerline Adapters

Dimensions in inches (mm)

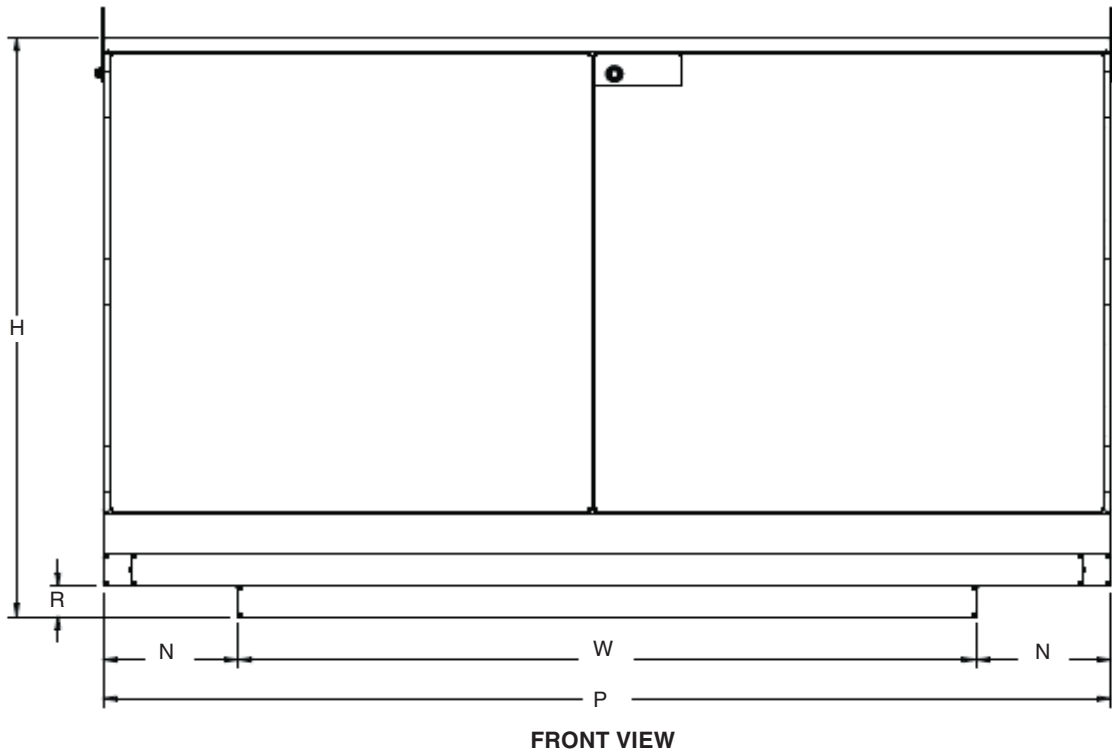

Table 18. Front Dimensions

Vista SD Switchgear Model	PME Replacement	Voltage, kV (IEC rating)	H	N	P	R	W
422	PME 9	15 (12)	56 (1422)	8¼ (210)	91½ (2324)	3 (76)	75 (1905)
		27 (24)	60 (1524)	¾ (95)		6⅞ (175)	84 (2134)
440	PME 10	15 (12)	56 (1422)	8¼ (210)	91½ (2324)	3 (76)	75 (1905)
		27 (24)	60 (1524)	¾ (95)		6⅞ (175)	84 (2134)
431	PME 11	15 (12)	56 (1422)	8¼ (210)	91½ (2324)	3 (76)	75 (1905)
		27 (24)	60 (1524)	¾ (95)		6⅞ (175)	84 (2134)
413	PME 12	15 (12)	56 (1422)	8¼ (210)	91½ (2324)	3 (76)	75 (1905)
		27 (24)	60 (1524)	¾ (95)		6⅞ (175)	84 (2134)

Vista® SD Underground Distribution Switchgear

Vista SD Underground Distribution Switchgear PME Configurations with Cable-Centerline Adapters

Dimensions in inches (mm)

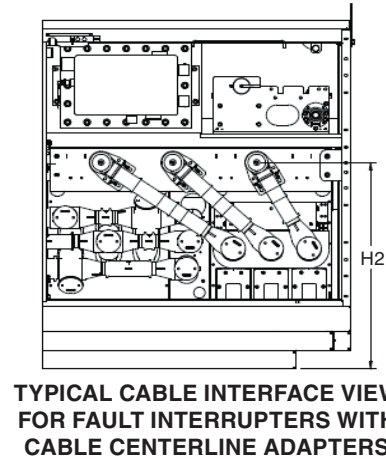
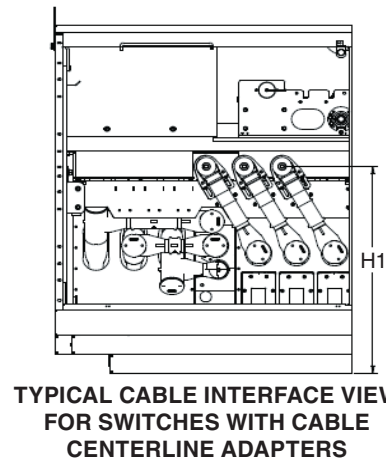
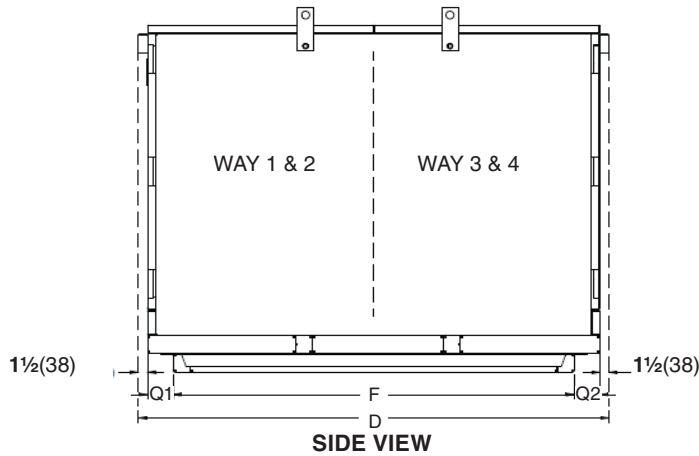

Table 19. Side and Cable Interface Dimensions

Vista SD Switchgear Model	PME Replacement	Voltage, kV (IEC rating)	D	F	H1	H2	Q1	Q2
422	PME 9	15 (12)	71½ (1816)	66¾ (1695)	33 (838)	33 (838)	7/8 (22)	7/8 (22)
		27 (24)	84¾ (2153)	81¾ (2076)	34¼ (870)	38¾ (984)	—	—
440	PME 10	15 (12)	80½ (2045)	72¾ (1848)	33 (838)	—	2¾ (60)	2¾ (60)
		27 (24)	92 (2337)	88¼ (2242)	34¼ (870)	—	¾ (10)	¾ (10)
431	PME 11	15 (12)	80½ (2045)	72¾ (1848)	33 (838)	33 (838)	2¾ (60)	2¾ (60)
		27 (24)	92 (2337)	88¼ (2242)	34¼ (870)	38¾ (984)	¾ (10)	¾ (10)
413	PME 12	15 (12)	80½ (2045)	66¾ (1695)	33 (838)	33 (838)	5¾ (137)	5¾ (137)
		27 (24)	84¾ (2153)	81¾ (2076)	34¼ (870)	38¾ (984)	—	—

Vista SD Underground Distribution Switchgear
PME Configurations with Cable-Centerline Adapters

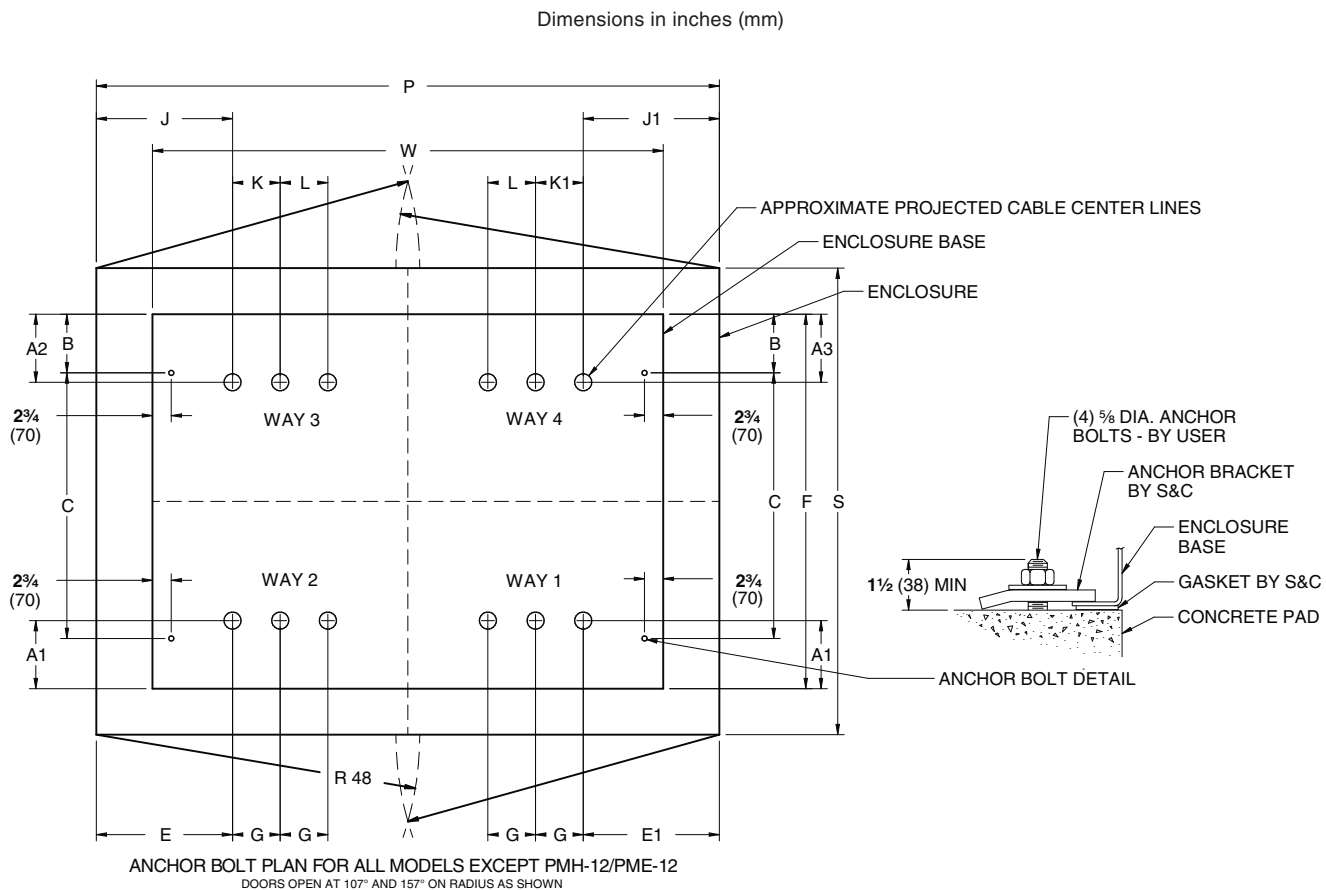

Table 20. Anchor Bolt Plan Dimensions for Models 422, 440 and 431

Vista SD Switchgear Model	PME Replacement	Voltage, kV (IEC rating)	A1	A2	A3	B	C	E	E1	F	G
422	PME 9	15 (12)	14 ⁵ / ₈ (371)	6 (152)	6 (152)	8 ⁵ / ₈ (219)	49 ¹ / ₂ (1257)	22 ⁷ / ₈ (581)	22 ⁷ / ₈ (581)	66 ³ / ₄ (1695)	5 ³ / ₄ (146)
		27 (24)	17 ³ / ₄ (451)	9 (229)	9 (229)	14 ⁷ / ₈ (378)	52 (1321)	19 ¹ / ₄ (489)	19 ¹ / ₄ (489)	81 ³ / ₄ (2076)	
440	PME 10	15 (12)	14 (356)	14 (356)	14 (356)	8 ⁵ / ₈ (219)	55 ¹ / ₂ (1410)	22 ⁵ / ₈ (575)	22 ⁵ / ₈ (575)	72 ³ / ₄ (1848)	5 ³ / ₄ (146)
		27 (24)	14 ⁵ / ₈ (371)	15 ¹ / ₂ (394)	15 ¹ / ₂ (394)	14 ⁷ / ₈ (378)	58 ¹ / ₂ (1486)	19 ¹ / ₄ (489)	19 ¹ / ₄ (489)	88 ¹ / ₄ (2242)	
431	PME 11	15 (12)	14 ¹ / ₈ (359)	8 (203)	13 ⁷ / ₈ (352)	8 ⁵ / ₈ (219)	55 ¹ / ₂ (1410)	22 ⁷ / ₈ (581)	22 ⁷ / ₈ (581)	72 ³ / ₄ (1848)	5 ³ / ₄ (146)
		27 (24)	18 ¹ / ₂ (470)	7 ¹ / ₄ (184)	19 (483)	14 ⁷ / ₈ (378)	58 ¹ / ₂ (1486)	19 ³ / ₈ (492)	19 ³ / ₈ (492)	88 ¹ / ₄ (2242)	

TABLE CONTINUED ►

Vista® SD Underground Distribution Switchgear

Vista SD Underground Distribution Switchgear PME Configurations with Cable-Centerline Adapters

Dimensions in inches (mm)

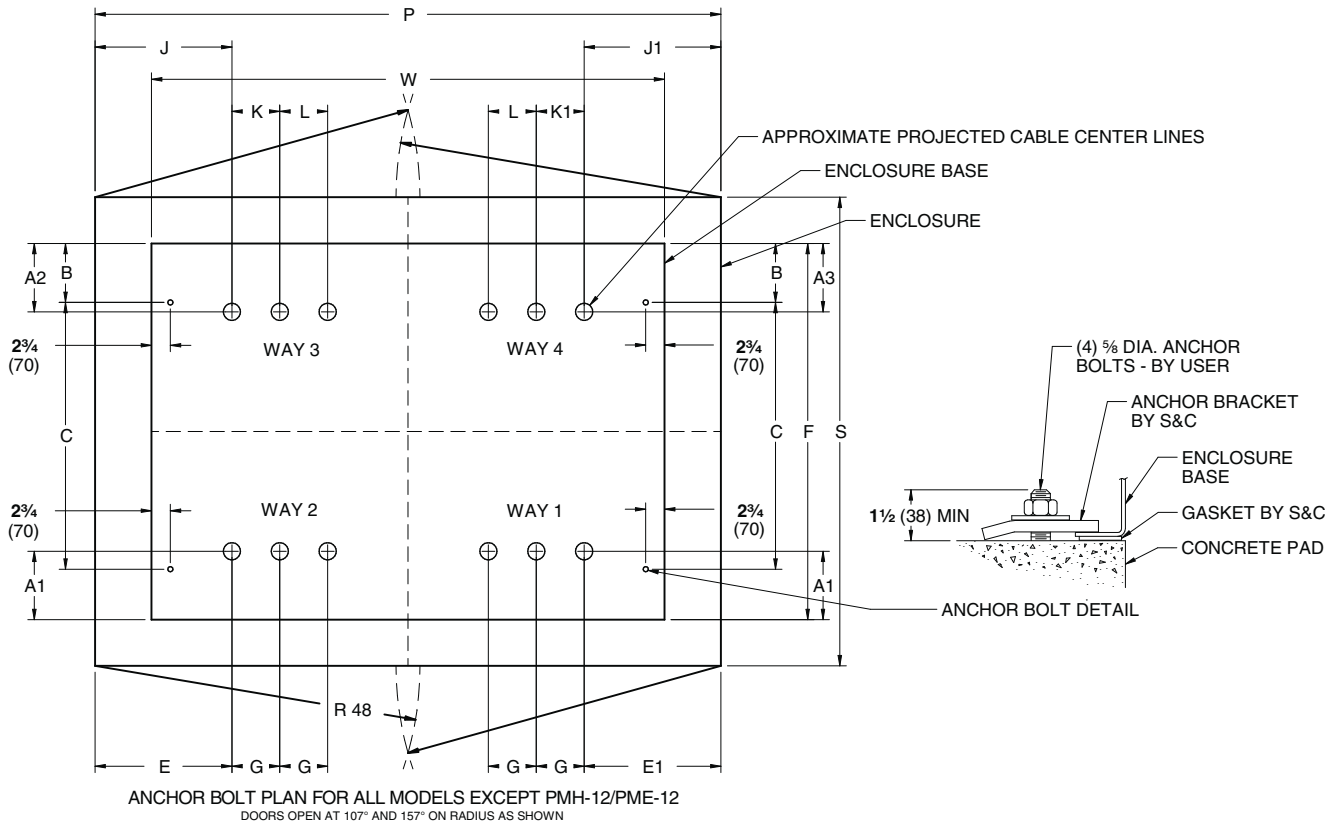

Table 20. Anchor Bolt Plan Dimensions for Models 422, 440 and 431—Continued

Vista SD Switchgear Model	PME Replacement	Voltage, kV (IEC rating)	J	J1	K	K1	L	P	S	W
422	PME 9	15 (12)	14 ¹ / ₈ (359)	14 ¹ / ₈ (359)	12 ³ / ₄ (324)	12 ³ / ₄ (324)	10 ⁷ / ₈ (276)	91 ¹ / ₂ (2324)	68 ¹ / ₂ (1740)	75 (1905)
		27 (24)	9 ⁵ / ₈ (244)	9 ⁵ / ₈ (244)	15 ³ / ₈ (391)	15 ³ / ₈ (391)	11 (279)		81 ¹ / ₄ (2076)	84 (2134)
440	PME 10	15 (12)	21 (533)	21 (533)	10 ⁷ / ₈ (276)	10 ⁷ / ₈ (276)	5 ³ / ₄ (146)	91 ¹ / ₂ (2324)	77 ¹ / ₂ (1969)	75 (1905)
		27 (24)	17 ⁵ / ₈ (448)	17 ⁵ / ₈ (448)	5 ³ / ₄ (146)	5 ³ / ₄ (146)	11 ⁵ / ₈ (289)		89 (2261)	84 (2134)
431	PME 11	15 (12)	14 ¹ / ₈ (359)	21 ¹ / ₈ (537)	12 ³ / ₄ (324)	5 ³ / ₄ (146)	10 ⁷ / ₈ (276)	91 ¹ / ₂ (2324)	77 ¹ / ₂ (1969)	75 (1905)
		27 (24)	9 ⁵ / ₈ (244)	17 ³ / ₄ (451)	15 ³ / ₈ (391)		11 ¹ / ₄ (286)		89 (2261)	84 (2134)

Vista SD Underground Distribution Switchgear
PME Configurations with Cable-Centerline Adapters

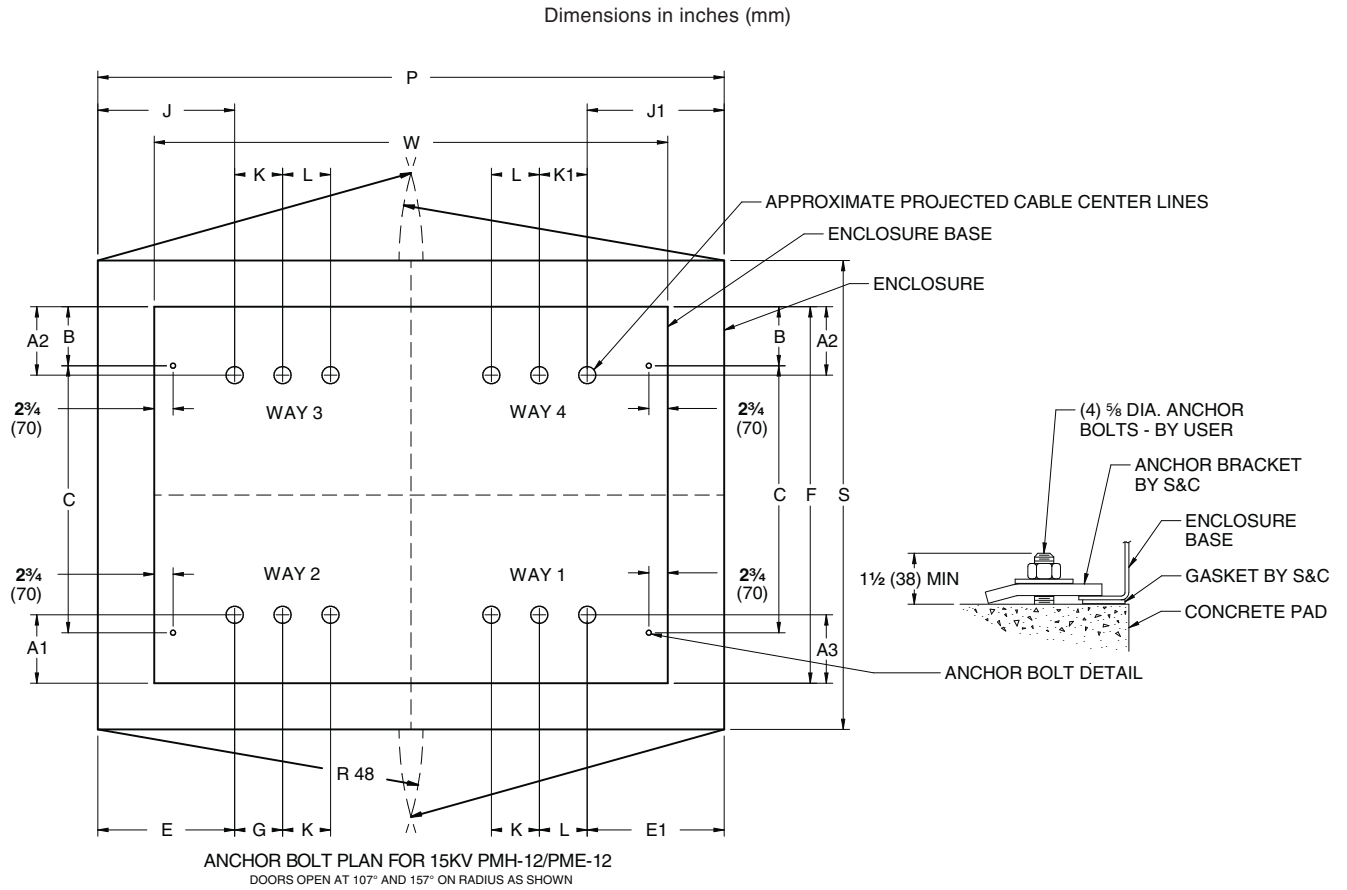

Table 21. Anchor Bolt Plan Dimensions for Model 413 at 15 kV

Vista SD Switchgear Model	PME Replacement	Voltage, kV (IEC rating)	A1	A2	A3	B	C	E	E1	F	G
413	PME 12	15 (12)	13 ¹ / ₈ (333)	5 (127)	6 ⁵ / ₈ (168)	8 ⁸ / ₁₆ (219)	49 ¹ / ₂ (1257)	21 ¹ / ₈ (537)	14 ¹ / ₈ (359)	66 ³ / ₄ (1695)	5 ³ / ₄ (146)

TABLE CONTINUED ►

Vista® SD Underground Distribution Switchgear

Vista SD Underground Distribution Switchgear PME Configurations with Cable-Centerline Adapters

Dimensions in inches (mm)

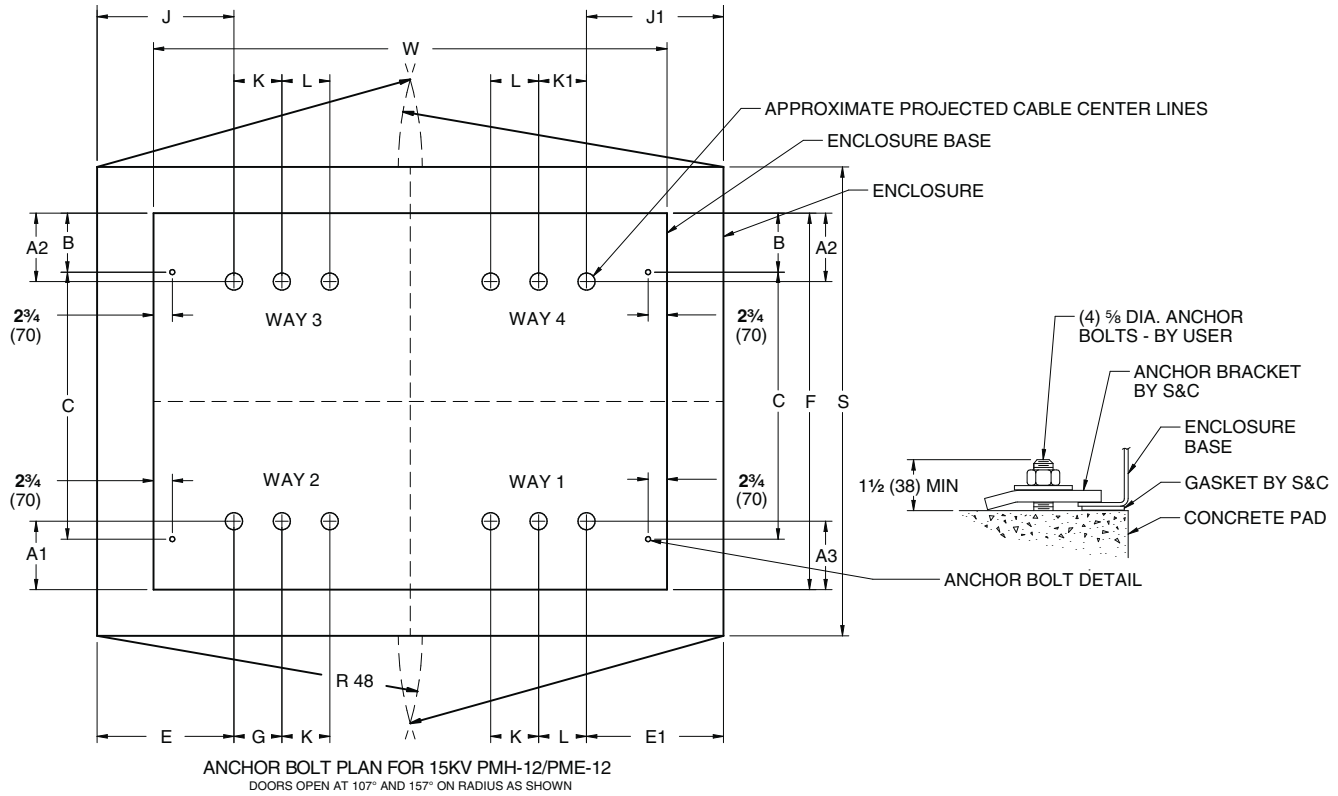

Table 21. Anchor Bolt Plan Dimensions for Model 413 at 15 kV—Continued

Vista SD Switchgear Model	PME Replacement	Voltage, kV (IEC rating)	J	J1	K	K1	L	P	S	W
413	PME 12	15 (12)	10 ³ / ₄ (273)	10 ³ / ₄ (273)	10 ⁷ / ₈ (276)	10 ⁷ / ₈ (276)	12 ³ / ₄ (324)	91 ¹ / ₂ (2324)	77 ¹ / ₂ (1969)	75 (1905)

Vista SD Underground Distribution Switchgear
PME Configurations with Cable-Centerline Adapters

Dimensions in inches (mm)

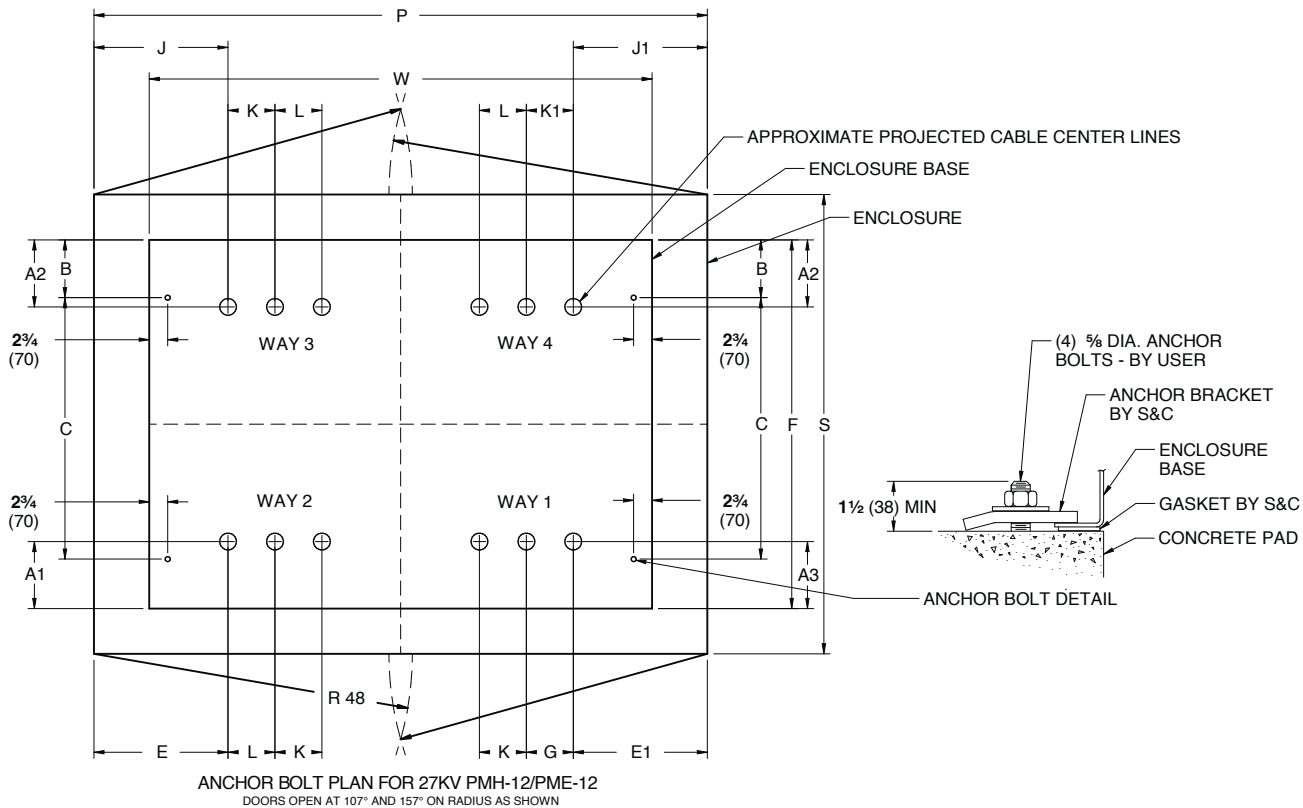

Table 22. Anchor Bolt Plan Dimensions for Model 413 at 27 kV

Vista SD Switchgear Model	PME Replacement	Voltage, kV (IEC rating)	A1	A2	A3	B	C	E	E1	F	G
413	PME 12	27 (24)	17 ³ / ₄ (451)	9 (229)	9 (229)	14 ⁷ / ₈ (378)	52 (1321)	17 ⁵ / ₈ (448)	9 ⁵ / ₈ (244)	81 ³ / ₄ (2076)	15 ⁵ / ₈ (391)

TABLE CONTINUED ►

Vista® SD Underground Distribution Switchgear

Vista SD Underground Distribution Switchgear PME Configurations with Cable-Centerline Adapters

Dimensions in inches (mm)

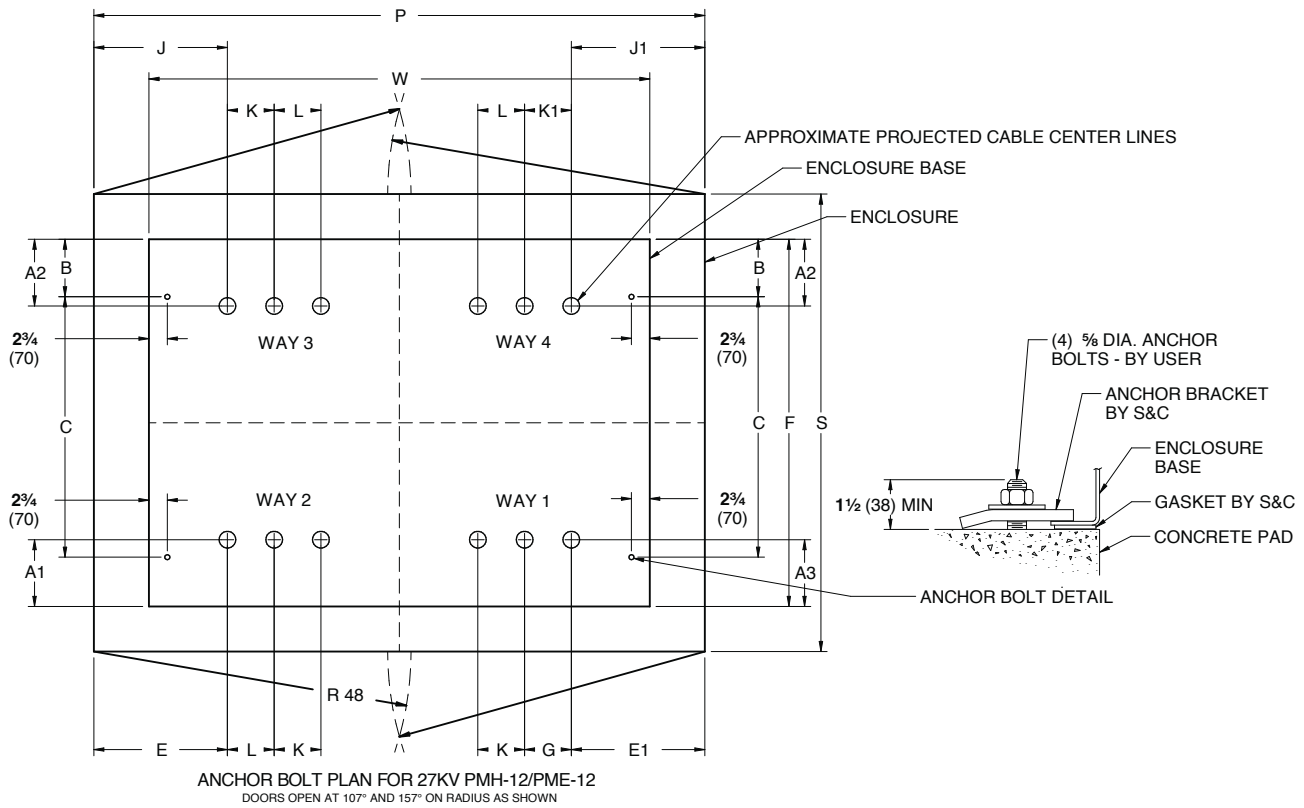

Table 22. Anchor Bolt Plan Dimensions for Model 413 at 27 kV—Continued

Vista SD Switchgear Model	PME Replacement	Voltage, kV (IEC rating)	J	J1	K	K1	L	P	S	W
413	PME 12	27 (24)	12 ¹ / ₈ (308)	12 ¹ / ₈ (308)	11 ³ / ₈ (289)	11 ³ / ₈ (289)	5 ³ / ₄ (146)	91 ¹ / ₂ (2324)	81 ³ / ₄ (2076)	84 (2134)

Vista SD Underground Distribution Switchgear
PME Configurations without Cable-Centerline Adapters

Dimensions in inches (mm)

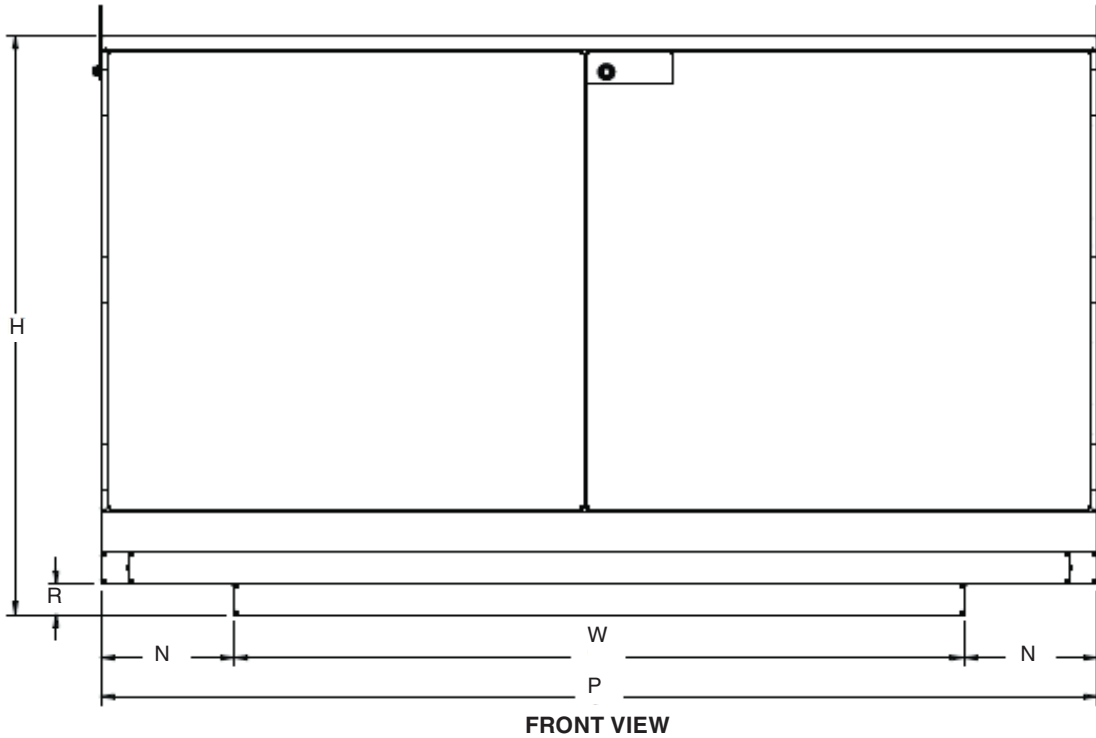

Table 23. Front Dimensions

Vista SD Switchgear Model	PME Replacement	Voltage, kV (IEC rating)	H	N	P	R	W
422	PME 9	15 (12)	56 (1422)	8¼ (210)	91½ (2324)	3 (76)	75 (1905)
		27 (24)	60 (1524)	¾ (95)		6⅞ (175)	84 (2134)
440	PME 10	15 (12)	56 (1422)	8¼ (210)	91½ (2324)	3 (76)	75 (1905)
		27 (24)	60 (1524)	¾ (95)		6⅞ (175)	84 (2134)
431	PME 11	15 (12)	56 (1422)	8¼ (210)	91½ (2324)	3 (76)	75 (1905)
		27 (24)	60 (1524)	¾ (95)		6⅞ (175)	84 (2134)
413	PME 12	15 (12)	56 (1422)	8¼ (210)	91½ (2324)	3 (76)	75 (1905)
		27 (24)	60 (1524)	¾ (95)		6⅞ (175)	84 (2134)

Vista® SD Underground Distribution Switchgear

Vista SD Underground Distribution Switchgear PME Configurations without Cable-Centerline Adapters

Dimensions in inches (mm)

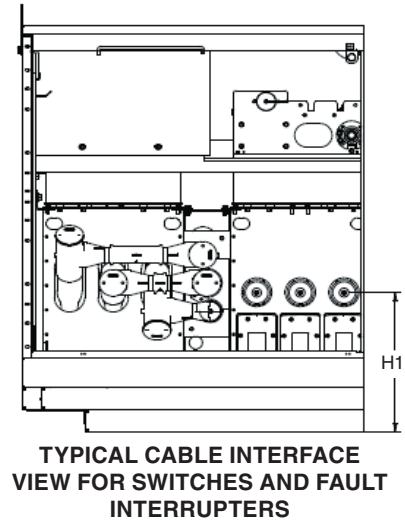
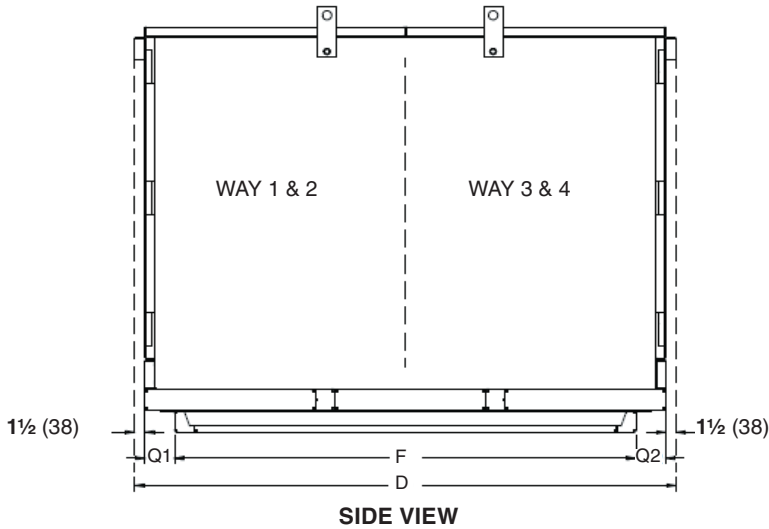

Table 24. Side and Cable Interface Dimensions

Vista SD Switchgear Model	PME Replacement	Voltage, kV (IEC rating)	D	F	H1	Q1	Q2
422	PME 9	15 (12)	71½ (1816)	66¾ (1695)	19¼ (489)	7⁄8 (22)	7⁄8 (22)
		27 (24)	84¾ (2153)	81¾ (2076)	23 (584)	—	—
440	PME 10	15 (12)	80½ (2045)	72¾ (1848)	19¼ (489)	2¾ (60)	2¾ (60)
		27 (24)	92 (2337)	88¼ (2242)	23 (584)	¾ (10)	¾ (10)
431	PME 11	15 (12)	80½ (2045)	72¾ (1848)	19¼ (489)	2¾ (60)	2¾ (60)
		27 (24)	92 (2337)	88¼ (2242)	23 (584)	¾ (10)	¾ (10)
413	PME 12	15 (12)	80½ (2045)	66¾ (1695)	19¼ (489)	5¾ (137)	5¾ (137)
		27 (24)	84¾ (2153)	81¾ (2076)	23 (584)	—	—

Vista SD Underground Distribution Switchgear
PME Configurations without Cable-Centerline Adapters

Dimensions in inches (mm)

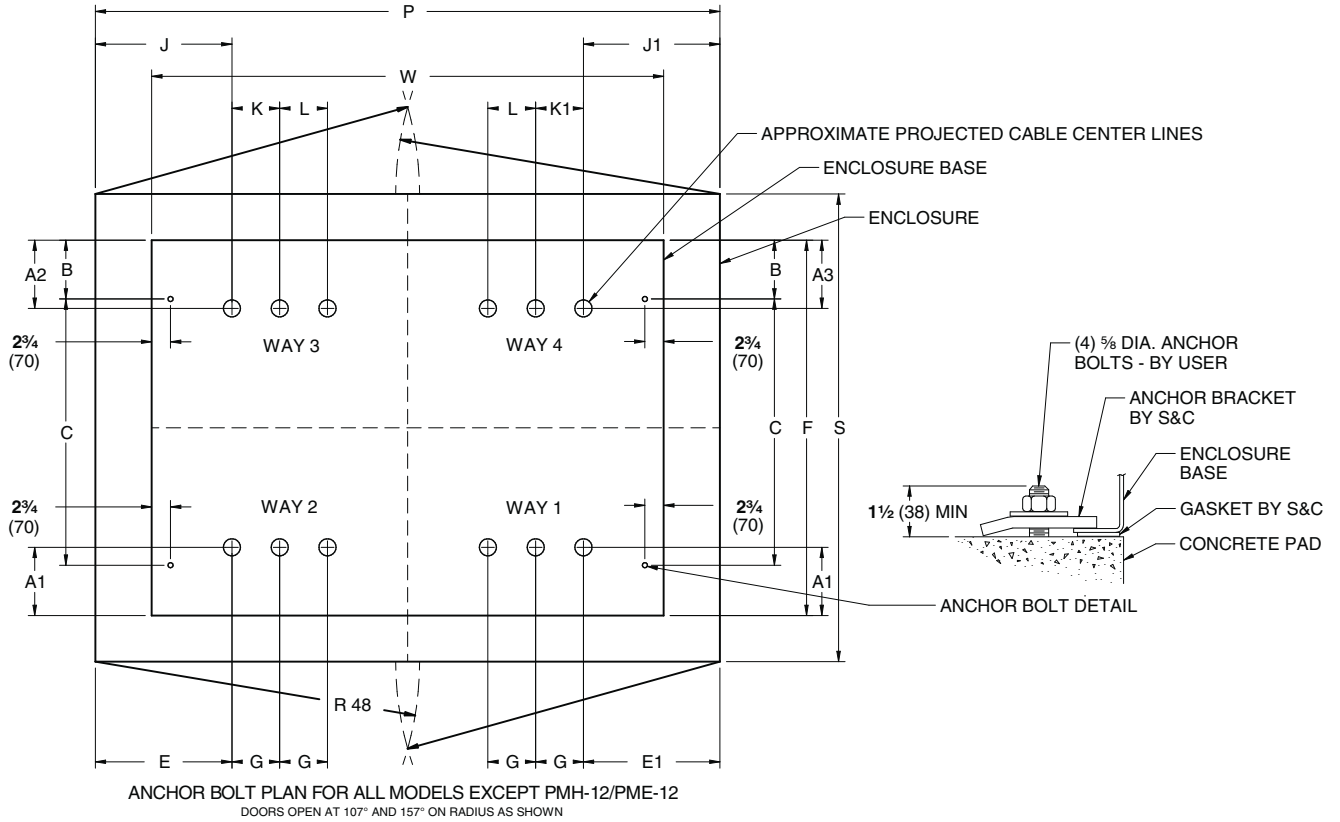

Table 25. Anchor Bolt Plan Dimensions for Models 422, 440 and 431

Vista SD Switchgear Model	PME Replacement	Voltage, kV (IEC rating)	A1	A2	A3	B	C	E	E1	F	G
422	PME 9	15 (12)	16 ⁵ / ₈ (422)	10 ⁵ / ₈ (270)	10 ⁵ / ₈ (270)	8 ⁵ / ₈ (219)	49 ¹ / ₂ (1257)	30 ³ / ₄ (781)	30 ³ / ₄ (781)	66 ³ / ₄ (1695)	5 ³ / ₄ (146)
		27 (24)	19 ³ / ₄ (502)	13 ⁵ / ₈ (346)	13 ⁵ / ₈ (346)	14 ⁷ / ₈ (378)	52 (1321)			81 ³ / ₄ (2076)	
440	PME 10	15 (12)	16 (406)	16 (406)	16 (406)	8 ⁵ / ₈ (219)	55 ¹ / ₂ (1410)	30 ³ / ₄ (781)	30 ³ / ₄ (781)	72 ³ / ₄ (1848)	5 ³ / ₄ (146)
		27 (24)	16 ⁵ / ₈ (422)	29 ¹ / ₄ (743)	29 ¹ / ₄ (743)	14 ⁷ / ₈ (378)	58 ¹ / ₂ (1486)			88 ¹ / ₄ (2242)	
431	PME 11	15 (12)	16 ¹ / ₈ (410)	12 ⁷ / ₈ (327)	15 ⁷ / ₈ (403)	8 ⁵ / ₈ (219)	55 ¹ / ₂ (1410)	30 ³ / ₄ (781)	30 ³ / ₄ (781)	72 ³ / ₄ (1848)	5 ³ / ₄ (146)
		27 (24)	20 ¹ / ₂ (521)	19 ¹ / ₂ (495)	25 ¹ / ₂ (648)	14 ⁷ / ₈ (378)	58 ¹ / ₂ (1486)			88 ¹ / ₄ (2242)	

TABLE CONTINUED ►

Vista SD Underground Distribution Switchgear PME Configurations without Cable-Centerline Adapters

Dimensions in inches (mm)

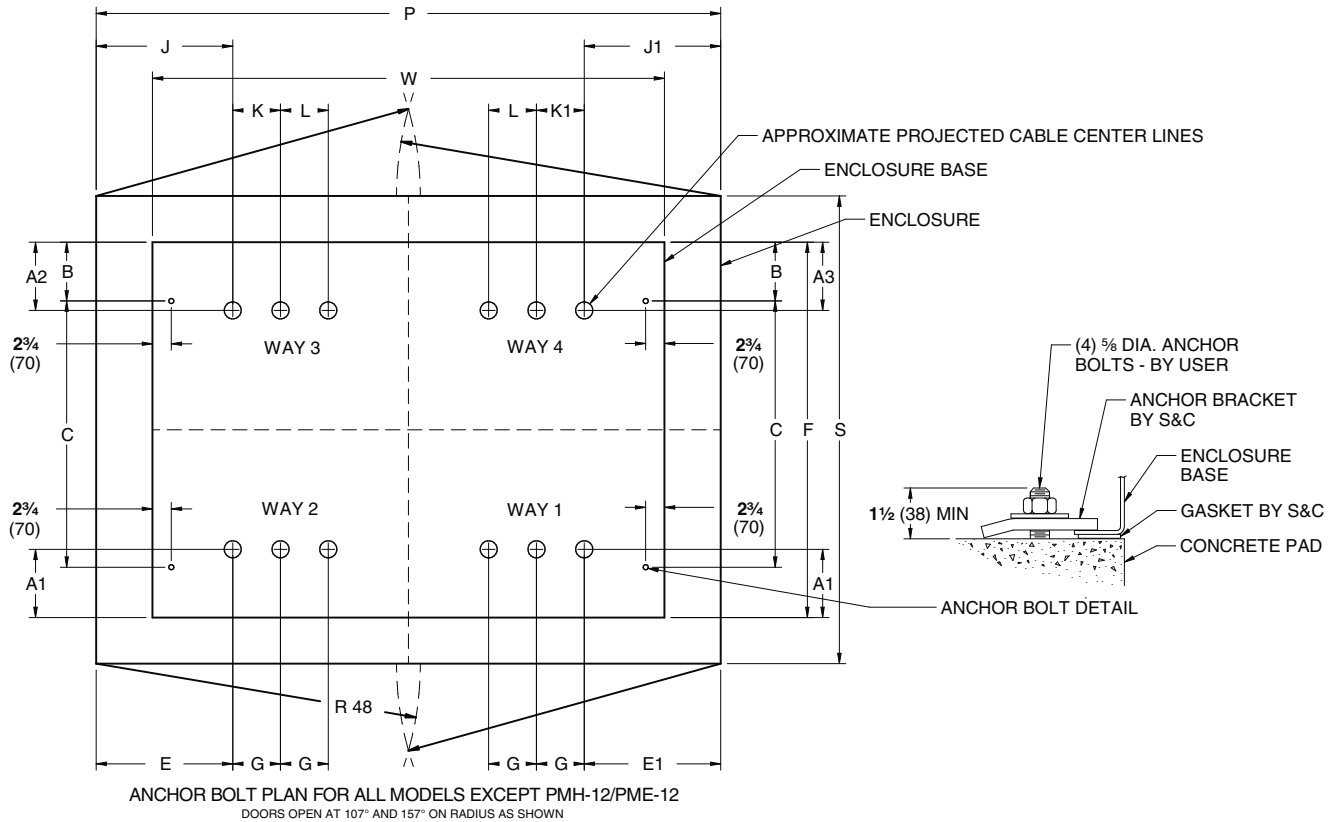

Table 25. Anchor Bolt Plan Dimensions for Models 422, 440 and 431—Continued

Vista SD Switchgear Model	PME Replacement	Voltage, kV (IEC rating)	J	J1	K	K1	L	P	S	W
422	PME 9	15 (12)	6 ¹ / ₈ (156)	6 ¹ / ₈ (156)	5 ³ / ₄ (146)	5 ³ / ₄ (146)	5 ³ / ₄ (146)	91 ¹ / ₂ (2324)	68 ¹ / ₂ (1740)	75 (1905)
		27 (24)							81 ³ / ₄ (2076)	84 (2134)
440	PME 10	15 (12)	6 ⁵ / ₈ (168)	6 ⁵ / ₈ (168)	5 ³ / ₄ (146)	5 ³ / ₄ (146)	5 ³ / ₄ (146)	91 ¹ / ₂ (2324)	77 ¹ / ₂ (1969)	75 (1905)
		27 (24)	6 ¹ / ₈ (156)	6 ¹ / ₈ (156)					89 (2261)	84 (2134)
431	PME 11	15 (12)	6 ¹ / ₈ (156)	6 ¹ / ₈ (156)	5 ³ / ₄ (146)	5 ³ / ₄ (146)	5 ³ / ₄ (146)	91 ¹ / ₂ (2324)	77 ¹ / ₂ (1969)	75 (1905)
		27 (24)							89 (2261)	84 (2134)

Vista SD Underground Distribution Switchgear
PME Configurations without Cable-Centerline Adapters

Dimensions in inches (mm)

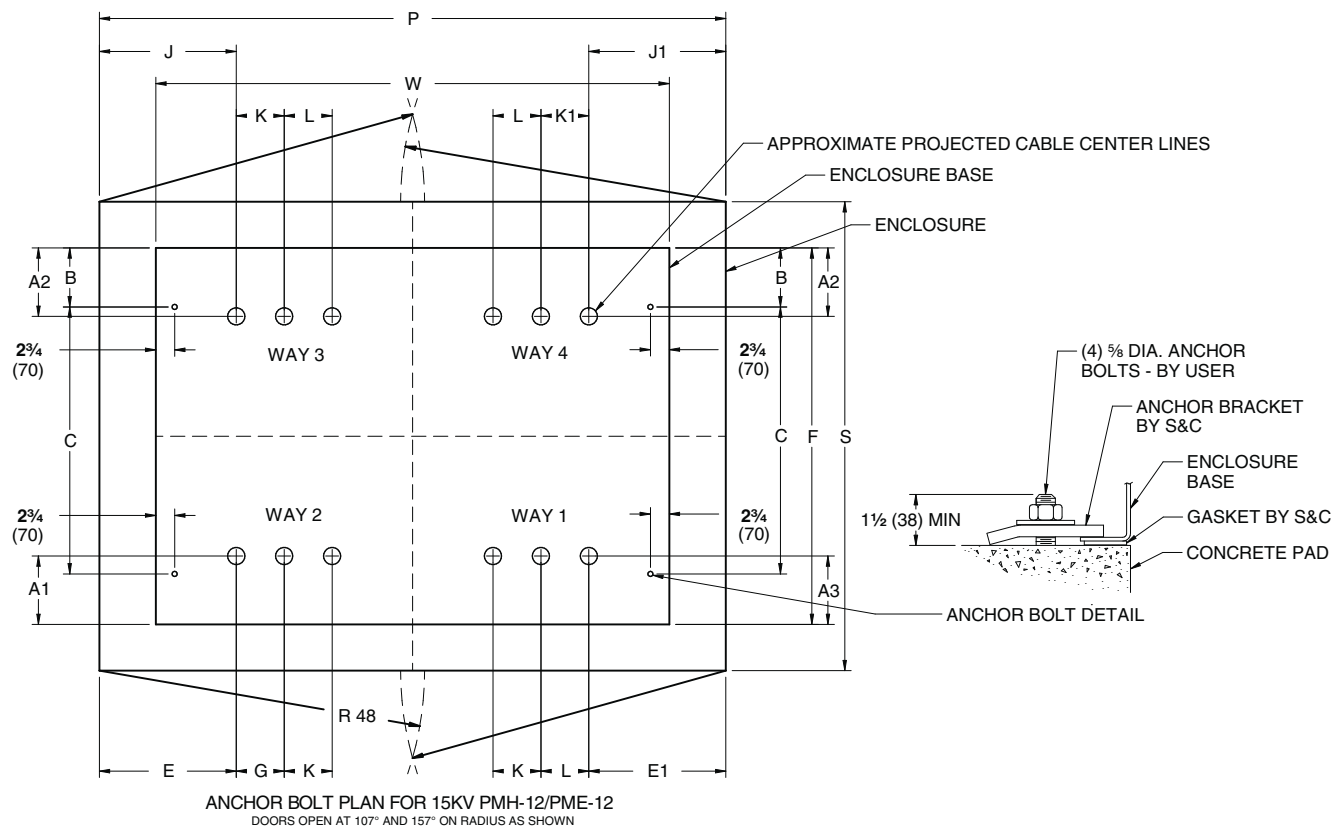

Table 26. Anchor Bolt Plan Dimensions for Model 413 at 15 kV

Vista SD Switchgear Model	PME Replacement	Voltage, kV (IEC rating)	A1	A2	A3	B	C	E	E1	F	G
413	PME 12	15 (12)	15 1/8 (384)	9 7/8 (251)	11 1/2 (292)	8 5/8 (219)	49 1/2 (1257)	6 1/8 (156)	6 1/8 (156)	66 3/4 (1695)	5 3/4 (146)

TABLE CONTINUED ►

Vista® SD Underground Distribution Switchgear

Vista SD Underground Distribution Switchgear PME Configurations without Cable-Centerline Adapters

Dimensions in inches (mm)

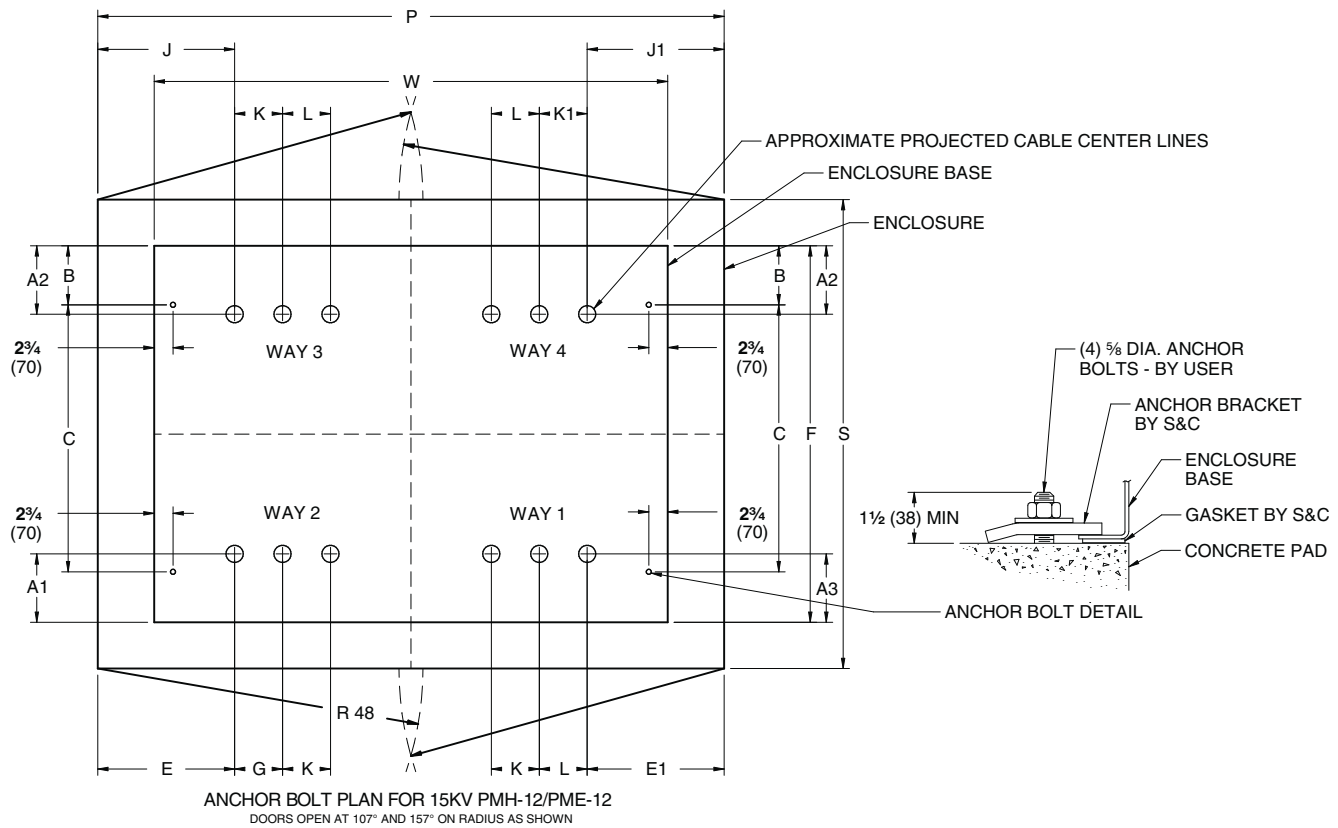

Table 26. Anchor Bolt Plan Dimensions for Model 413 at 15 kV—Continued

Vista SD Switchgear Model	PME Replacement	Voltage, kV (IEC rating)	J	J1	K	K1	L	P	S	W
413	PME 12	15 (12)	30¾ (781)	30¾ (781)	5¾ (146)	5¾ (146)	5¾ (146)	91½ (2324)	77½ (1969)	75 (1905)

Vista SD Underground Distribution Switchgear
PME Configurations without Cable-Centerline Adapters

Dimensions in inches (mm)

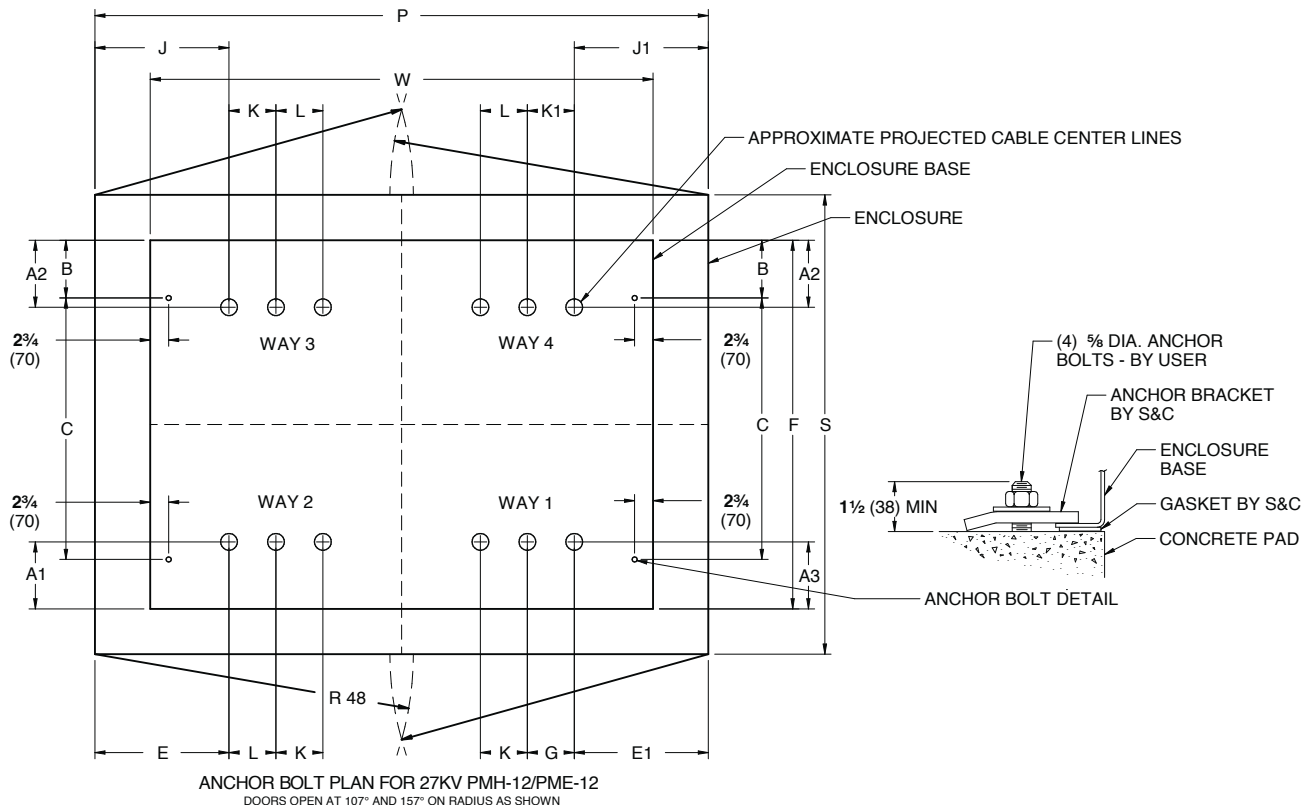

Table 27. Anchor Bolt Plan Dimensions for Model 413 at 27 kV

Vista SD Switchgear Model	PME Replacement	Voltage, kV (IEC rating)	A1	A2	A3	B	C	E	E1	F	G
413	PME 12	27 (24)	19 3/4 (502)	13 3/4 (349)	13 3/4 (349)	14 7/8 (378)	52 (1321)	6 1/8 (156)	6 1/8 (156)	8 1/4 (2076)	5 3/4 (146)

TABLE CONTINUED ►

Vista SD Underground Distribution Switchgear PME Configurations without Cable-Centerline Adapters

Dimensions in inches (mm)

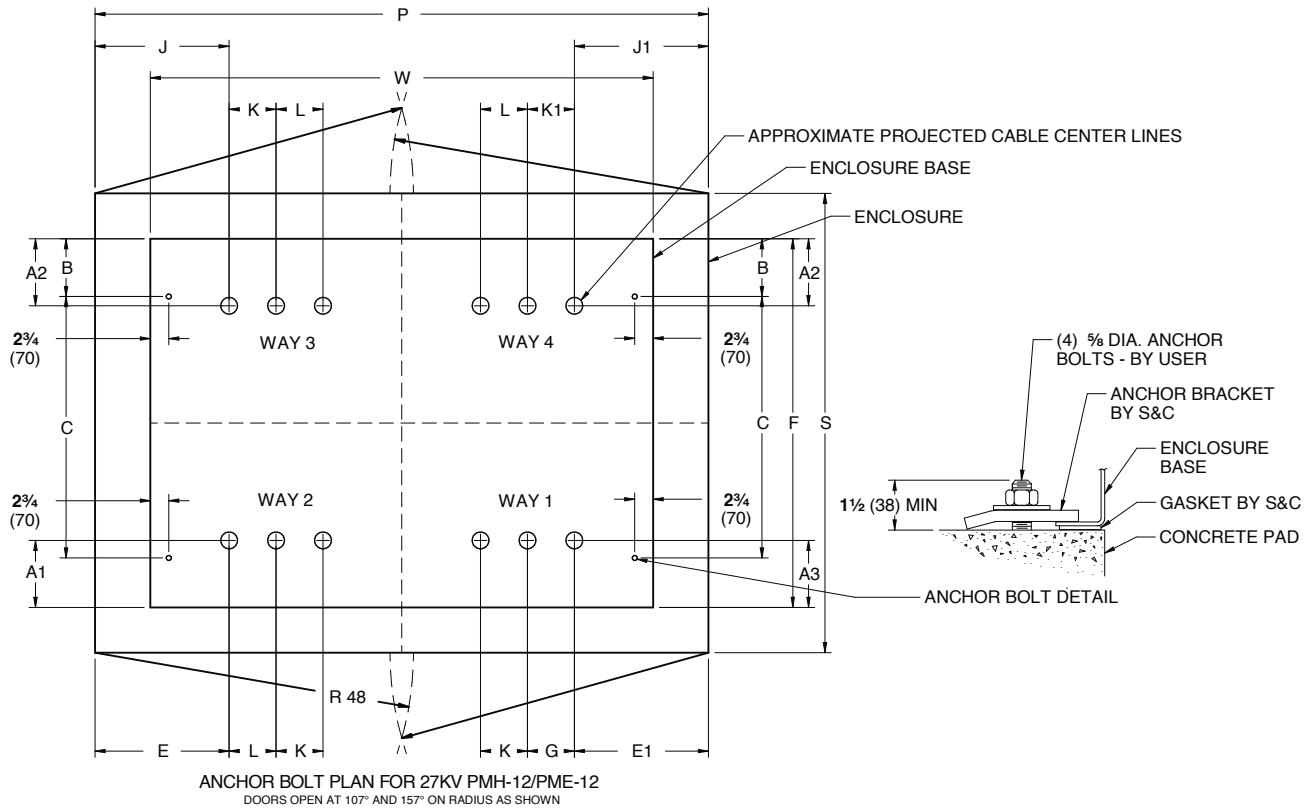

Table 27. Anchor Bolt Plan Dimensions for Model 413 at 27 kV—Continued

Vista SD Switchgear Model	PME Replacement	Voltage, kV (IEC rating)	J	J1	K	K1	L	P	S	W
413	PME 12	27 (24)	30¾ (781)	30¾ (781)	5¾ (146)	5¾ (146)	5¾ (146)	91½ (2324)	81¾ (2076)	84 (2134)