



S&C Regulator Bypass Switches

Type XL (Sequenced) and Type NL (Nonsequenced)
Outdoor Distribution (14.4 kV and 25 kV)

Application

S&C Regulator Bypass Switches are station-type devices used to bypass and isolate voltage regulators for maintenance. They can also be used to bypass and isolate other devices, such as current transformers. These switches feature an interrupter for breaking the magnetizing current of the regulator.

Type XL Regulator Bypass Switches provide built-in mechanical interlocking, sequencing, and synchronization.

Type NL Regulator Bypass Switches perform the same functions as Type XL Regulator Bypass Switches, except that the sequencing of operations is left to the operator. Type NL Regulator Bypass Switches are used in applications where a 1200-ampere continuous rating is required or where it is desired to bypass the voltage regulator with its shunt winding energized (bypass blade closed, disconnect blade open) so that mechanical and electrical testing can be carried out.

Construction

Type XL Regulator Bypass Switches

The Type XL Regulator Bypass Switch is a station-type device featuring an interrupter for breaking the magnetizing current of the regulator. Current interruption takes place within the interrupter, without external arc or flame. See Figure 1.

The disconnect, interrupter, and bypass blades are all of double-member hard-drawn copper construction. Silver-to-silver contacts are used throughout the switch. Silver-alloy buttons are brazed into the bypass blade; disconnect and interrupter blades are clad with extra-thick high-density, low-porosity silver. Stationary contacts employ brazed silver-nickel overlays or are heavily clad with silver by S&C's Silver-Weld process. Surface structure of the stationary contacts differs from that of the blade contact to prevent sticking, galling, or seizing. Contacts won't weld, burn, or pit from overcurrents.

Stainless steel loading springs behind the contact areas of the blades, including the hinged end, provide a smooth, positive wiping action and keep the contacts under constant pressure. This feature is particularly important in the case of the bypass

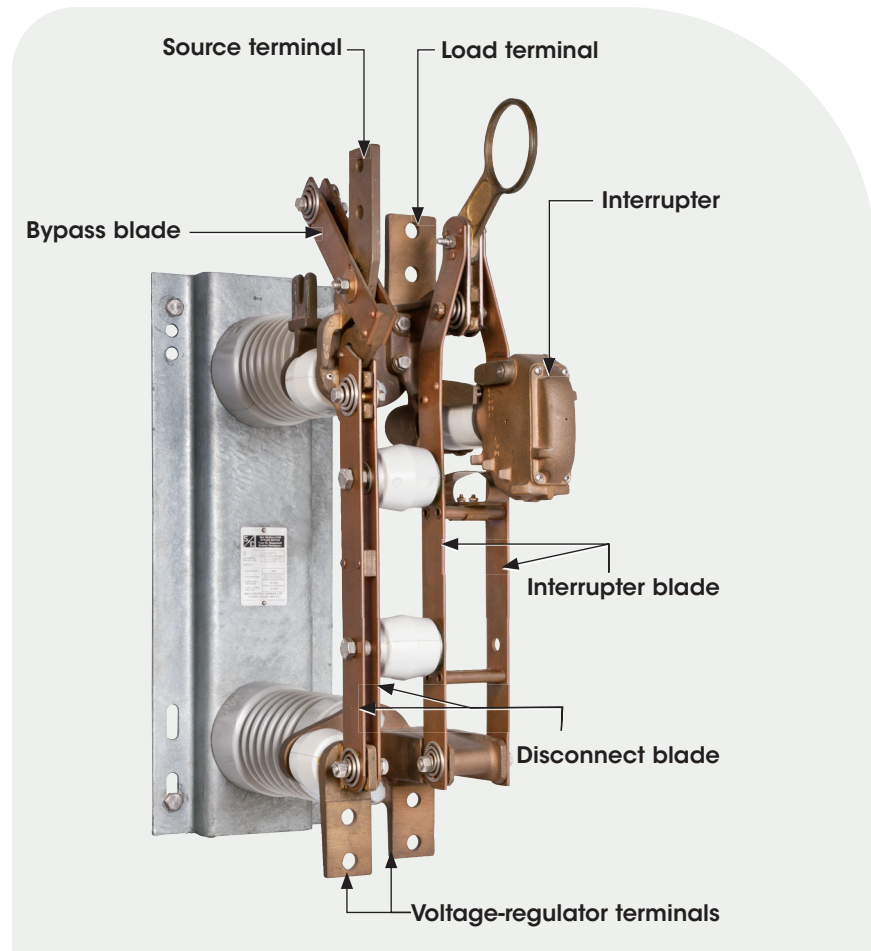

Figure 1. Construction of Type XL Regulator Bypass Switches.

blade, which is normally open and must carry full load current after long periods of contact-surface exposure to the elements.

Special attention has been given to the operation and alignment of the disconnect blade through the use of stainless-steel hardware and rigid anchoring of the disconnect blade to the interrupter blade. Ease of operation is ensured by a floating contact alignment, and a carefully positioned and proportioned hook ring.

Type XL Regulator Bypass Switches are offered with a choice of Cypoxy™ Insulator or porcelain station-post insulators. Cypoxy station-post insulators are nontracking, self-scouring, and nonweathering, and they meet or exceed the electrical and mechanical-strength requirements established in ANSI/NEMA Standard C29.9 (1983) for porcelain standard-strength station-post insulators.

Type NL Regulator Bypass Switches

The Type NL Regulator Bypass Switch, like the Type XL Regulator Bypass Switch, is a station-type device featuring an interrupter for breaking the magnetizing current of the regulator. Current interruption takes place within the interrupter, without external arc or flame. See Figure 2.

The disconnect, interrupter, and bypass blades are all of double-member hard-drawn copper construction. Silver-to-silver contacts are used throughout the switch. Silver-alloy buttons are brazed into each of the blades. Stationary contacts feature silver-nickel alloy overlays, brazed in place, then coined for hardness, contour, and low porosity.

Beryllium-copper loading springs behind the contact areas of the blades, including the hinge-end, provide a smooth, positive wiping action, and keep the contacts under constant pressure. This feature is particularly important for the bypass blade, which is normally in an open position and must carry full-load current after long periods of contact-surface exposure to the elements.

Type NL Regulator Bypass Switches are offered with a choice of Cyproxy or porcelain station-post insulators, as described on page 2 for Type XL Regulator Bypass Switches.

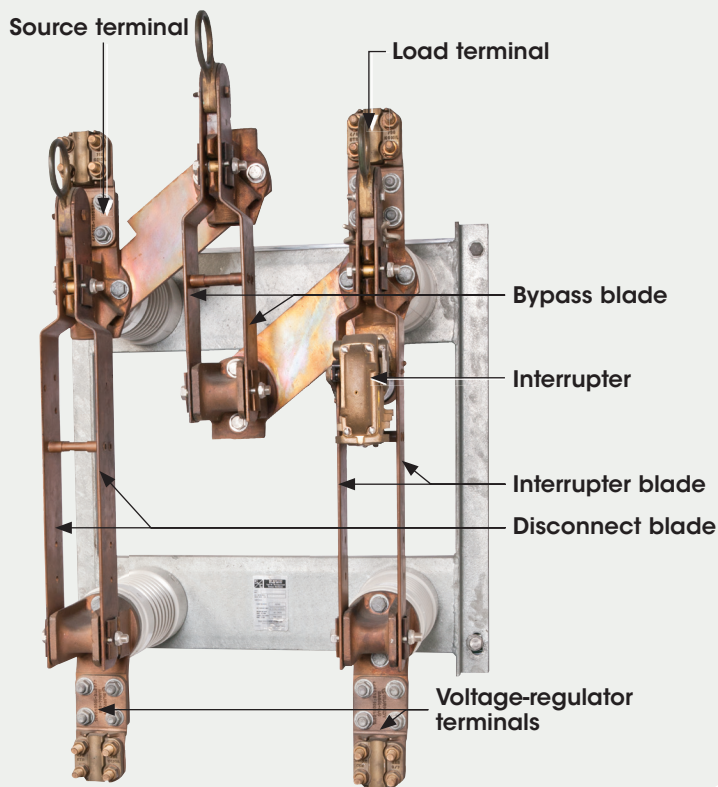

Figure 2. Construction of Type NL Regulator Bypass Switches.

Operation

Type XL Regulator Bypass Switches

Built-in mechanical interlocking, sequencing, and synchronization are featured. See Figure 3 on page 4. During the opening stroke, the bypass blade closes first, bypassing the regulator to prevent interruption of service. Next, the disconnect blade opens the regulator series winding. Finally, when the interrupter blade opens, interruption of shunt-winding magnetizing current takes place within the interrupter, and the regulator is isolated from the line.

During the closing stroke when restoring the regulator to service, the switching sequence is reversed automatically, putting the voltage regulator back into service without dropping the load.

Type NL Regulator Bypass Switches

Manual sequencing of operation is required. See Figure 4 on page 5. To isolate the regulator, the operator must first close the bypass blade to prevent interruption of service. Next, he must open the disconnect blade to open the regulator series winding. Finally, he must open the interrupter blade, interruption of shunt-winding magnetizing current takes place within the interrupter, and the regulator is isolated from the line.

To place the regulator back into service, the operator must reverse the sequence of operation described above.

During testing, the voltage regulator may be bypassed with its shunt winding energized by closing the bypass blade and then opening the disconnect blade.

Regulator bypass switches must not be operated until the automatic control circuits of the associated regulator tap changers have been opened and the tap changers have been moved to the neutral position.

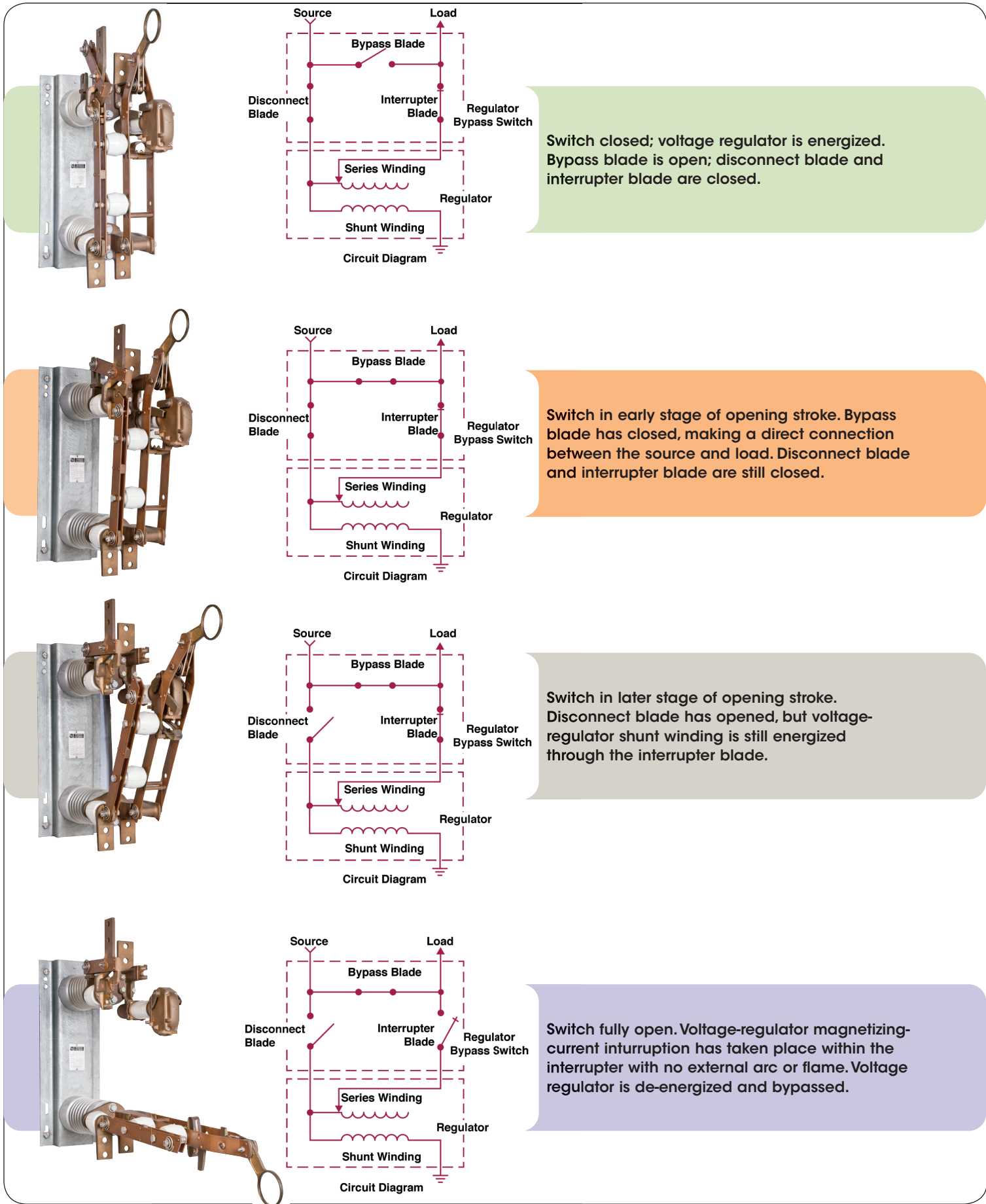
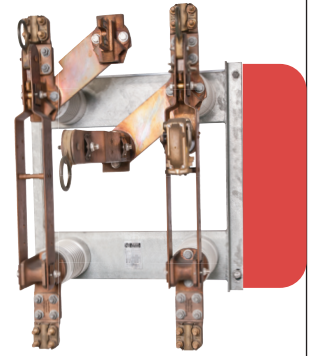
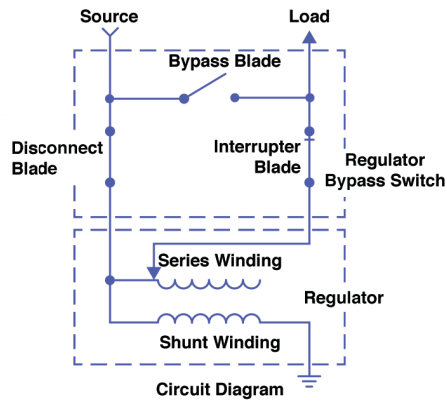
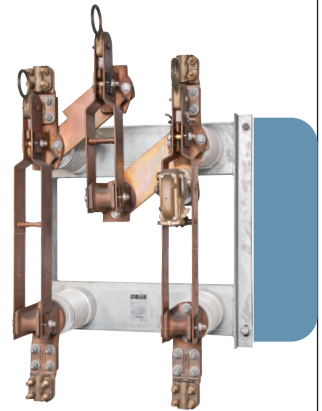
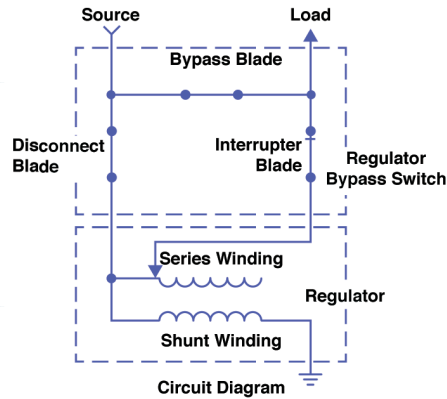

Figure 3. Sequence of operation of Type XL Regulator Bypass Switches.

Voltage regulator is energized. Bypass blade is open; disconnect blade and interrupter blade are closed.



First step to isolate regulator: Bypass blade is closed. Voltage-regulator series winding is now shunted by bypass blade. Disconnect blade and interrupter blade remain in closed position.



Second step to isolate regulator: Disconnect blade is opened-disconnecting the voltage-regulator series winding. Bypass blade is still closed and voltage-regulator shunt winding remains energized through the interrupter blade.

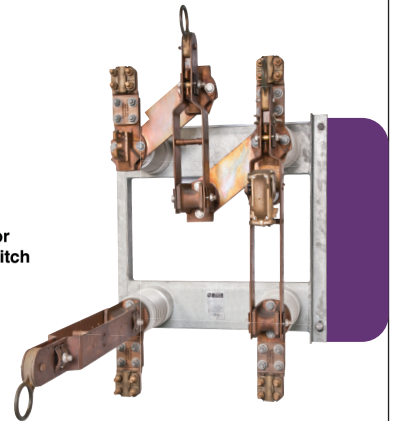
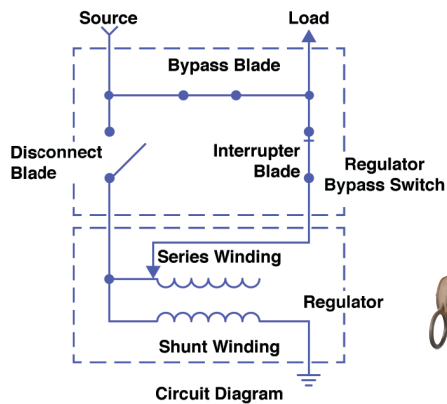

Third step to isolate regulator: Interrupter blade is opened and voltage-regulator magnetizing current is interrupted inside the interrupter, with no external arc or flame. Bypass blade is still closed; disconnect blade is still open.

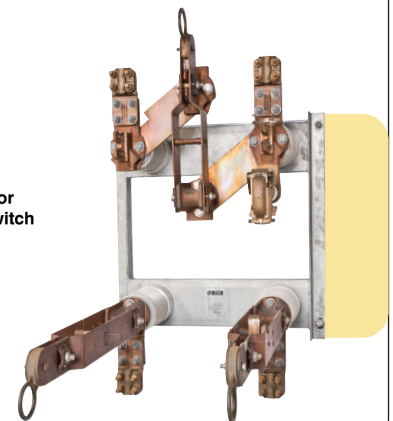
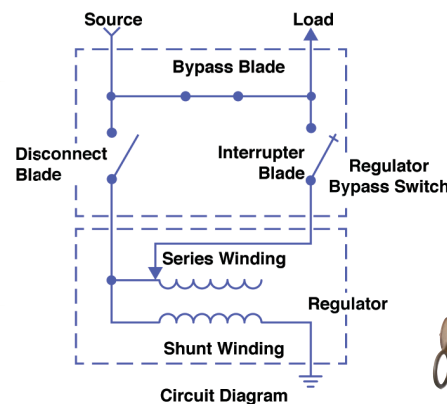
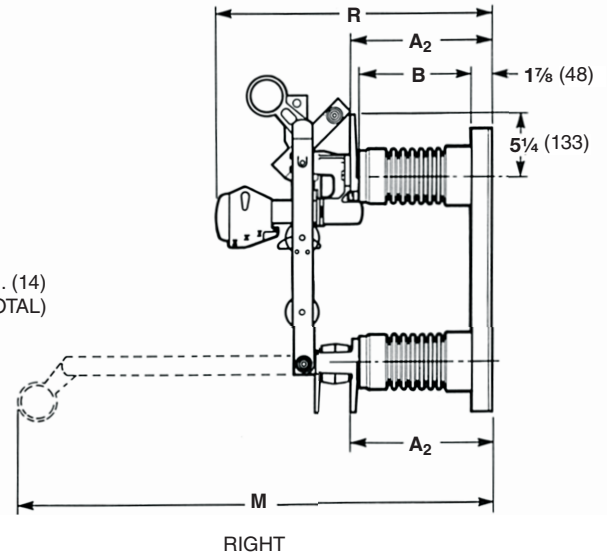
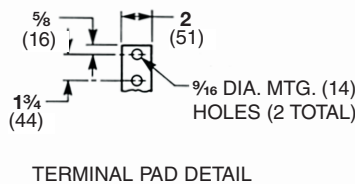
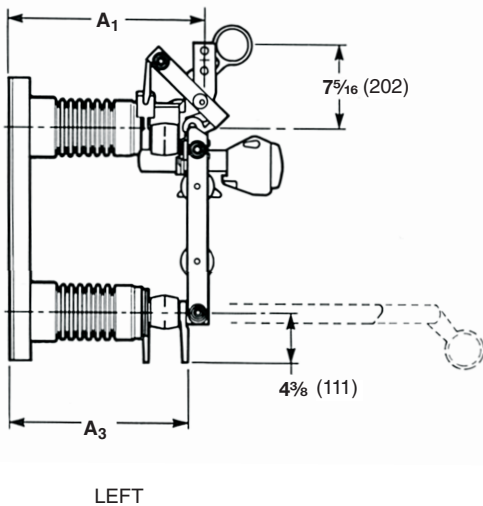
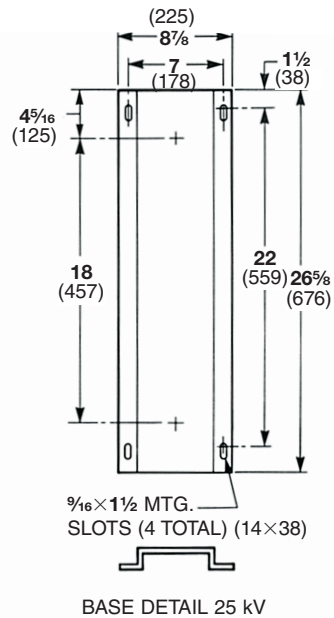
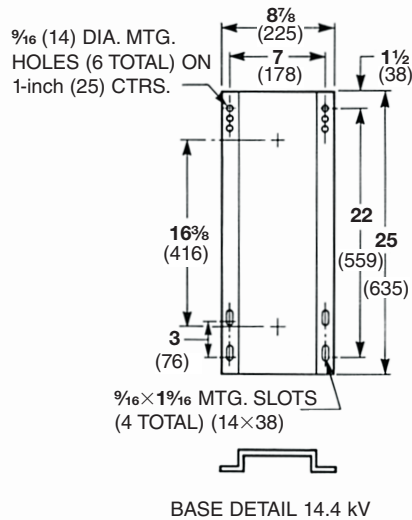
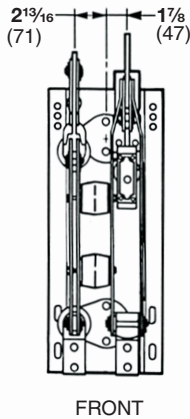

Figure 4. Sequence of operation of Type NL Regulator Bypass Switches.

Specifications

Type XL (Sequenced), Single-Pole Style, Inches (mm)



Rating					Catalog Number		Dimensions in Inches (mm)						Net Wt., Lbs. (kg)	
kV			Amperes, RMS		Cypoxy Station-Post Insulators ②	Porcelain Station-Post Insulators	A1	A2	A3	B	M	R	Cypoxy Station-Post Insulators	Porcelain Station-Post Insulators
Nom.	Max	BIL	Cont.	Mom. ①										
14.4	17.0	110	600	30 000	333412R7-E	333412R7	17 5/8 (448)	12 5/8 (321)	16 (406)	10 (254)	42 3/8 (1076)	24 3/8 (619)	93 (42)	107 (48)
25	27	150	600	30 000	333413R1-E	333413R1	21 5/8 (549)	16 5/8 (422)	20 (508)	14 (356)	46 1/2 (1181)	28 1/2 (724)	98 (44)	125 (57)

① Three-second rating: 18,500 amperes RMS, symmetrical.

② Cypoxy is the S&C trademark for S&C's cycloaliphatic epoxy resin system. Cypoxy is nontracking, self-scouring, nonweathering, and there's never a compromise of insulation integrity. S&C Cypoxy station-post

insulators meet or exceed the electrical and mechanical-strength requirements established in ANSI Standard C29.9 (1983) for porcelain standard-strength station-post insulators.

Type NL (Nonsequenced), Single-Pole Style, Inches (mm)

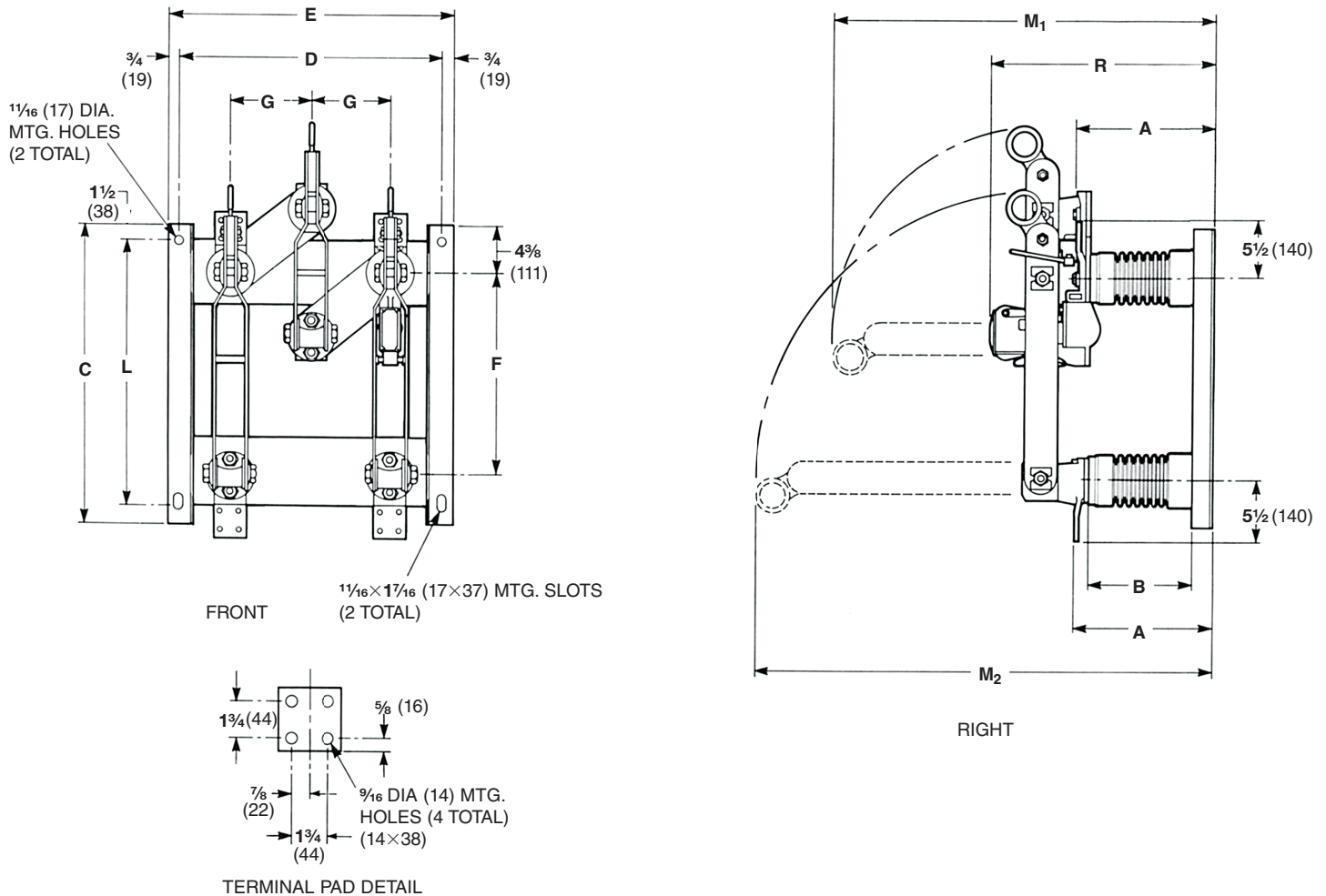

Rating					Catalog Number		Dimensions in Inches (mm)										Net Wt., Lbs. (kg)		
kV			Amperes, RMS		Cypoxy Station Post Insulators ②	Porcelain Station Post Insulators	A	B	C	D	E	F	G	L	M1	M2	R	Cypoxy Station-Post Insulators	Porcelain Station-Post Insulators
Nom.	Max	BIL	Cont.	Mom. ①															
14.4	17.0	110	1200	61 000	333602-E	333602	13 1/2 (343)	10 (254)	28 (711)	25 1/2 (648)	27 (686)	19 3/8 (492)	8 (203)	25 (635)	34 3/4 (883)	42 1/8 (1070)	23 1/2 (597)	189 (86)	217 (98)
25	27	150	1200	61 000	333603-E	333603	17 1/2 (444)	14 (356)	30 1/4 (768)	27 1/2 (698)	29 (737)	21 5/8 (549)	9 (229)	27 1/4 (692)	24 3/4 (629)	38 3/4 (984)	28 3/8 (721)	216 (98)	270 (122)

① Three-second rating: 40,000 amperes RMS, symmetrical.

② Cypoxy is the S&C trademark for S&C's cycloaliphatic epoxy resin system. Cypoxy is nontracking, self-scouring, and nonweathering, and there's never a compromise of insulation integrity. S&C Cypoxy station-

post insulators meet or exceed the electrical and mechanical-strength requirements established in ANSI Standard C29.9 (1983) for porcelain standard-strength station-post insulators.

Descriptive Bulletin 841-30

March 30, 2015

© S&C Electric Company 1978-2015, all rights reserved

Offices Worldwide ■ sandc.com



S&C ELECTRIC COMPANY

Excellence Through Innovation