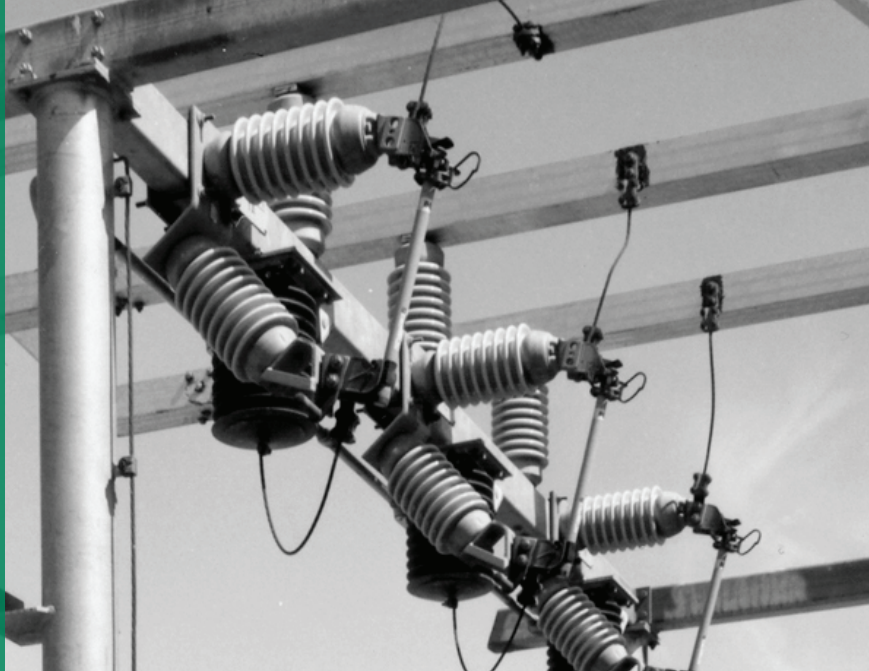


# SMD-20 POWER FUSES

OUTDOOR DISTRIBUTION  
(14.4 KV THROUGH 34.5 KV)



**SMD-20 Power Fuses offer full-fault-spectrum protection. They detect and interrupt all faults—large, medium, and small—even down to minimum melting current.**

## CONTENTS

<b>Introduction</b>	<b>1</b>
<b>Application Overview</b>	<b>3</b>
Transformer Protection	3
Line and Cable Protection (Sectionalizing)	3
Capacitor Bank Protection	4
No Need to Push Cutouts Beyond Their Limit	4
<b>Superior to Conventional Current-Limiting Fuses</b>	<b>6</b>
<b>Construction Details</b>	<b>7</b>
Reliable Latching	9
Superb Current Transfer	9
<b>The SMU-20® Fuse Unit</b>	<b>10</b>
The Fusible Element	11
Nondamageable Construction	11
<b>Features</b>	<b>14</b>
Fault Interruption	14
Positive Dropout Action	14
Easy to Handle	16
Easy to Close	16
<b>Easy to Operate with Loadbuster— The S&amp;C Loadbreak Tool</b>	<b>18</b>
<b>Mounting Styles and Ratings</b>	<b>20</b>

## Introduction

Power fuses are frequently used on distribution systems in locations where the capabilities and performance of fuse cutouts are not sufficient. However, not all power fuses are created equal, and some approaches to power fusing may cost more in nuisance operations and misoperations than many might believe.

Power fuses use a solid-material arc-extinguishing medium to quickly and quietly interrupt overcurrents. These materials are sensitive to water ingress, which can inhibit the proper operation of the fuse.

A common perception regarding power fuses is sealing the fuse off from the environment is the best way to avoid compromising the solid-material interrupting medium. However, this approach has long-term shortcomings. Sealed fuse units tend to experience degradation in their seals



## Introduction (continued)

---

over time. When the seal is compromised, the pressure differential between the environment and the interior of the fuse unit will suck water vapor into the fuse unit, damaging the arc-interrupting material and preventing the fuse from operating properly.

S&C's unique approach to SMU-20 Fuse Unit construction uses a breathable design that works to maintain equalized pressure between the environment and the interior of the fuse unit. When combined with the nondamageable fusible element design and tight tolerances for which S&C is known, SMD-20 Power Fuses provide many years of precise and reliable protection. SMD-20 Power Fuses offer:

- ◆ Unique, low-arc-energy fault interruption and mild exhaust
- ◆ Nondamageable fusible elements with 10% tolerances<sup>1</sup>
- ◆ Dropout after fault interruption to provide visual indication
- ◆ Pole-top or station mounting
- ◆ Loadbuster®—The S&C Loadbreak Tool operability for convenient load switching

SMD-20 Power Fuses, with their universal SMU-20 Fuse Units, provide reliable, economical protection for transformers and capacitors on outdoor distribution feeders and in distribution substations. See **Figure 1 on page 3**.

SMD-20 Power Fuses protect the system upstream, too. They operate promptly on short circuits, thus minimizing stress on the remainder of the system. And they isolate only the faulted segment, limiting the extent of service interruption.

SMD-20 Power Fuses also protect downstream lines and cables as well as downstream equipment, such as transformers and capacitors.

The positive dropout action of SMD-20 Power Fuses following fault interruption ensures permanent isolation of faulted circuits and equipment, and it provides clearly visible indication of fuse operation.

SMD-20 Power Fuses feature precision-engineered nondamageable silver or nickel-chrome fusible elements. Time-current characteristic (TCC) curves are precise and permanently accurate, ensuring dependable performance and continued reliability of system coordination plans. The precise TCC curves and nondamageability of SMD-20 Power Fuses permit source-side protective devices to be set for faster operation than may be practical with other power fuses or circuit breakers, thus providing better system protection without compromising coordination.

---

1 10% tolerances for 10E through 400E Standard speed power fuses, 15E through 200E Slow speed power fuses, 50E through 200E Very Slow speed power fuses, 6K through 200K power fuses, and 3DR through 20DR power fuses. 15% tolerances for 5E through 7E Standard speed power fuses, and 20% tolerances for 3K power fuses and 1A Standard speed power fuses for voltage-transformer applications.

**FIGURE 1.** An SMD-20 Power Fuse.



## TRANSFORMER PROTECTION

Installed on the primary side of a power transformer in a substation or a pole-mounted transformer on a distribution feeder, SMD-20 Power Fuses provide full fault-spectrum protection. They detect and interrupt all faults—large, medium, and small (even down to minimum melting current)—with line-to-line or line-to-ground voltage across the fuse, regardless of whether the fault is on the primary or secondary side and regardless of transformer winding connections. They also handle the full range of transient recovery-voltage severity associated with these conditions.

With the unique design and performance characteristics of SMD-20 Power Fuses, it's possible to fuse close to transformer full-load current without risking unwanted operation caused by routine overloads or harmless transient surges. Such close fusing, coupled with exceptional low-current fault-interrupting performance, ensures maximum protection per the transformer through-fault protection curve defined in ANSI standards for a broad range of secondary-side fault currents. The life-shortening thermal and mechanical stresses associated with prolonged transformer through-faults are minimized.

SMD-20 Power Fuses are ideal for protection of auxiliary (station service) transformers and voltage transformers. Regardless of the application, SMD-20 Power Fuses provide full fault-spectrum protection plus reliable, permanent, and precise coordination with line or secondary breakers and other power fuses.

## LINE AND CABLE PROTECTION (SECTIONALIZING)

Applied at pole-top locations on distribution feeders or at the secondary of distribution substation transformers, SMD-20 Power Fuses can interrupt all classes of permanent faults on overhead lines or underground cables. But they won't operate unnecessarily and aren't damaged by transient faults.

With their permanently accurate TCC curves and wide selection of available ampere ratings and speeds, SMD-20 Power Fuses are ideal for

coordination with substation reclosers or circuit breakers in “fuse-saving” schemes. They also provide excellent series coordination with other fuses whenever greater system segmentation is desired to limit the scope of outages following permanent faults. Because SMD-20 Power Fuses are Loadbuster tool-operable, the convenience and versatility of full-load switching can be provided anywhere on the distribution system.

### CAPACITOR BANK PROTECTION

SMD-20 Power Fuses are particularly well-suited for protection of pole-top or station capacitor banks. Their substantial continuous peak-load capability frequently permits the use of smaller ampere ratings than is possible with distribution fuse links, other makes of power fuses, or current-limiting fuses—and without nuisance fuse operations (“sneak-outs”) caused by capacitor-bank inrush or outrush currents. Close fusing with SMD-20 Power Fuses results in superior protection for the capacitor bank, so evolving faults within individual capacitor units—the most common mode of capacitor-unit failure—can be detected and cleared before case rupture occurs.

### NO NEED TO PUSH CUTOUTS BEYOND THEIR LIMIT

SMD-20 Power Fuses are an excellent alternative to cutouts where:

- ◆ System available fault current exceeds the capabilities of cutouts
- ◆ The noise and exhaust associated with cutout operation are unacceptable because of the application or environmental considerations

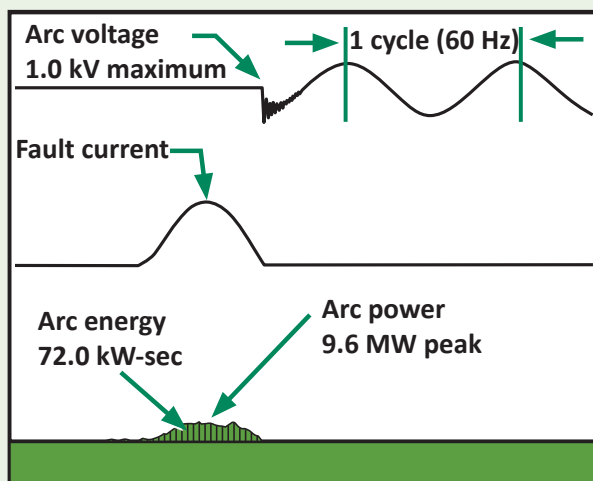
Distribution cutouts typically have fault-interrupting ratings of 16,000 amperes asymmetrical or less and may be subject to application restrictions at system voltages of 25 kV or higher. With their higher voltage and interrupting ratings, SMD-20 Power Fuses bridge the protection gap between cutouts and other, more-expensive, high-capacity power fuses or current-limiting fuses. As a result, there’s no need to over duty cutouts and settle for incomplete protection of system conductors or equipment.

SMD-20 Power Fuses provide full-fault-spectrum protection by means of a solid-material low-arc-energy technique of fault interruption having a mild exhaust. As shown in the oscillograms in **Figure 2 through Figure 4 on page 5**, tests have shown the arc energy of an SMD-20 Power Fuse is only 18% that of a double-vented cutout and just 20% that of a single-vented cutout. Peak arc power—one measure of exhaust energy—was 9.6 MW for the SMD-20 Power Fuse, compared to 96.8 MW

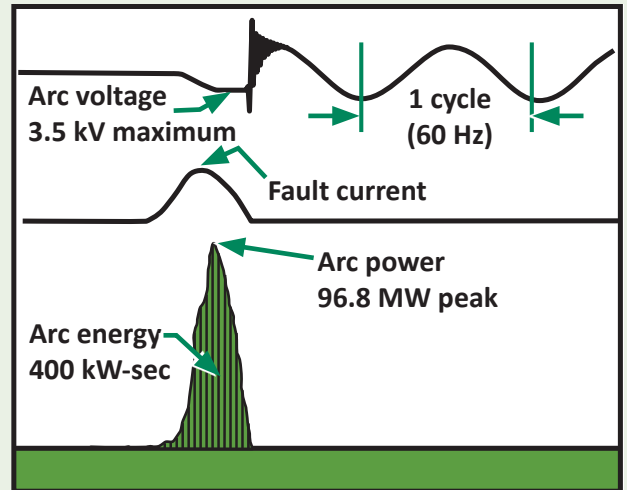
and 72.8 MW for the double-vented and single-vented cutouts respectively.

Likewise, arc voltage—an indirect measure of arc power—was substantially lower for the SMD-20 Power Fuse than for either of the cutouts. Consequently, the SMD-20 Power Fuse is quieter and gentler than a cutout.

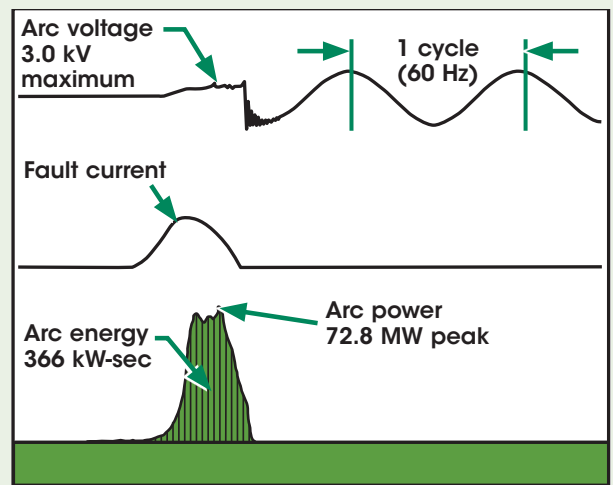
**FIGURE 2.** The arc energy of an SMD-20 Power Fuse.



**FIGURE 3.** The arc energy of a double-vented distribution fuse cutout.



**FIGURE 4.** The arc energy of a single-vented distribution fuse cutout.



# Superior to Conventional Current-Limiting Fuses

SMD-20 Power Fuses are a superior alternative to current-limiting fuses in applications where:

- ◆ Current-limiting fuses are unsuitable because of their less-than-adequate TCC curves and susceptibility to damage from surge currents (as are commonly experienced in outdoor distribution applications)
- ◆ High continuous-current requirements and fuse handling considerations make conventional current-limiting fuses impractical

Type SMD-20 Power Fuses have helically coiled silver fusible elements of solderless construction surrounded by air. The fusible elements are thus free of mechanical and thermal stress and confining support. As a result, they are not subject to damage—even by inrush currents that approach, but do not exceed, the fuse’s minimum melting TCC curve.

Current-limiting fuses, in contrast, have fusible elements comprised of a number of very fine diameter wires, or one or more perforated or notched ribbons, surrounded by, and in contact with, filler material such as silica sand. And in current-limiting fuses, the fusible element carries load current. Because of this construction, current-limiting fuses are susceptible to element damage from current surges that approach the fuse’s minimum-melting TCC curve. Such damage may be compounded on overhead distribution systems by repetitive current surges occasioned by **Open/Close** operations of upstream circuit reclosers.

Damage to the fusible elements of current-limiting fuses may shift or alter their TCC curves, resulting in a loss of complete coordination between the fuse and downstream overcurrent protective devices. Moreover, a damaged current-limiting fuse element may melt due to harmless inrush current, but the fuse may fail to clear the circuit because of insufficient power flow—with the fuse continuing to arc and burn internally because of load-current flow.

Because of the potential for damage to the fusible element, current-limiting fuse manufacturers typically require that, when applying the fuses, adjustments be made to the minimum-melting TCC curves. These adjustments, referred to as “safety zones” or “setback allowances,” range from 25% in terms of time to 25% in terms of current. The latter can result in an adjustment of 250% or more in terms of time, depending on the slope of the TCC curve at the point where the safety zone or setback allowance is measured.

Furthermore, most current-limiting fuses inherently have steep, relatively straight time-current characteristic curves that, together with the required large safety-zone or setback-allowance adjustments, force selection of higher fuse ampere ratings to withstand transformer magnetizing-inrush currents and hot- and cold-load pickup currents, and to coordinate with downstream protective devices. But selection of higher fuse ampere ratings results in reduced protection for the distribution system and equipment. Because the fuse ampere rating may substantially exceed transformer full-load current,

# Superior to Conventional Current-Limiting Fuses (continued)

coordination with upstream devices can be severely impaired.

Current-limiting fuses also are heavy and difficult to maneuver, particularly with a hotstick. Operating personnel must carefully steer these fuses when performing opening and closing operations.

SMD-20 Power Fuses, in contrast, are easy to handle. SMU-20 Fuse Units are light and readily maneuvered at the end of a hotstick. The positive, self-guiding action of the fuse hinge and trunnion permits nearly effortless opening and closing operations.

## Construction Details

The SMD-20 Power Fuse consists of a mounting and a replaceable SMU-20 Fuse Unit. See **page 20** through **page 25** for available mounting styles.

The mounting includes a base (or mounting bracket in the case of Overhead—Pole-Top Style), insulator(s), a latch-and-upper-contact assembly, a hinge-and-lower-contact assembly, and reusable upper and lower fuse-unit end-fittings. See **Figure 5 on page 8**.

Overhead—Pole-Top Style Mountings are offered with a choice of porcelain or—for mountings rated 14.4 kV and 25 kV only—a composite-polymer silicone insulator. Station-Style Mountings are offered with a choice of porcelain or S&C Cypoxy™ Insulator station post insulators.

Fuse-unit end-fittings are available separately, permitting users to equip spare SMU-20 Fuse Units for quick replacement.

# Construction Details (continued)

FIGURE 5. The components of an Overhead-Pole-Top Style SMD-20 Power Fuse.

Birdproof-design insulator—provides insulation characteristics higher than ANSI distribution-cutout standards and equal in most cases to ANSI switch and bus standards. Mounting bracket and hardware are included.

Latch-and-upper-contact assembly

Fuse unit upper end-fitting (reusable)

Loadbuster tool attachment hooks—provide self-guiding action for the fuse unit during closing

SMU-20 Fuse Unit—replaced after a fault-clearing operation

Fuse unit lower end-fitting (reusable)

Hinge-and-lower-contact assembly



## RELIABLE LATCHING

As shown in **Figure 6** and **Figure 7**, the latch rides over and drops in behind the roller on the fuse-unit upper end-fitting.

The impact-absorbing action of the spring-backed contact fingers prevents the fuse unit from recoiling from the latched position during closing. The fuse unit can't drop out because of vibration or shock.

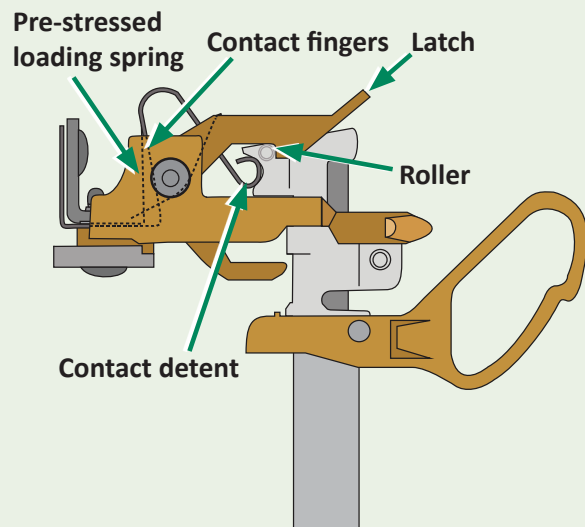
## SUPERB CURRENT TRANSFER

Superb current transfer between the SMU-20 Fuse Unit and the upper and lower contacts is ensured, even after exposure to the elements for an extended period of time. The wiping-in, rolling-out contact design of the upper contacts results in

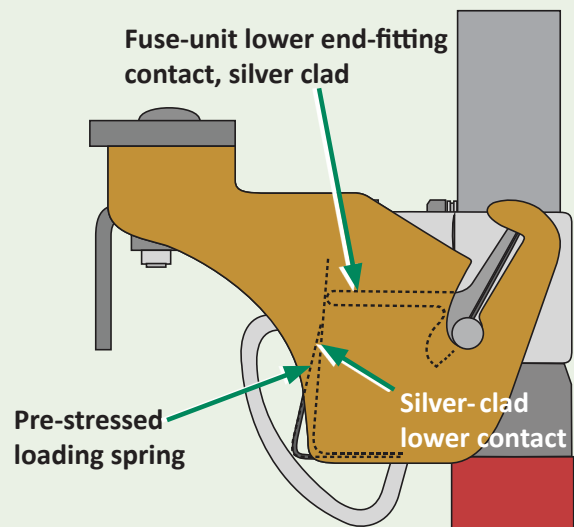
minimal electrical resistance between the upper contact assembly and the fuse unit. As the fuse unit is closed into the upper contact assembly, silver-clad contact fingers first engage and wipe the silver-clad surface of the fuse-unit upper end-fitting. Then, during latching, as the contact fingers enter the contact detent of the upper end-fitting, a high-pressure, low-resistance contact is created by flexing of the contact fingers, with backup from the pre-stressed loading spring.

The silver-clad lower contacts feature embossed surfaces for built-in wiping action, and they are backed up by pre-stressed loading springs for efficient current transfer between the lower contact assembly and the fuse-unit lower end-fitting.

**FIGURE 6.** The latch-and-upper-contact assembly (fully closed).



**FIGURE 7.** Lower contacts—silver-to-silver—provide a dual current path independent of the hinge pivot.



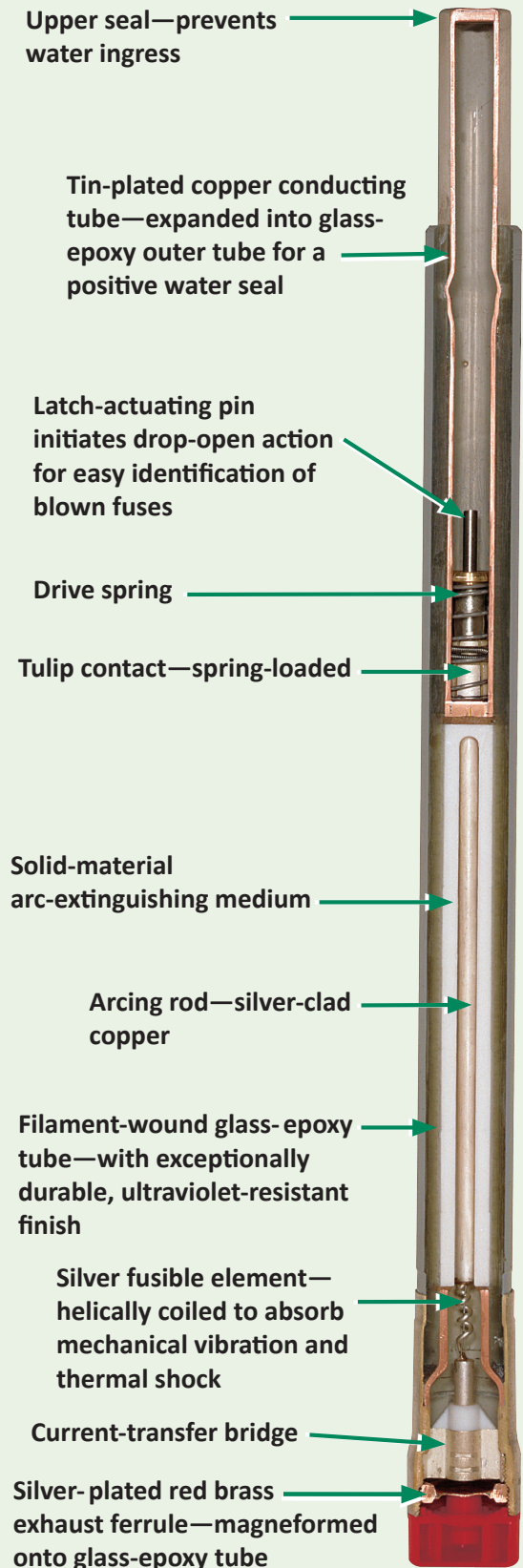
# The SMU-20® Fuse Unit

The SMU-20 Fuse Unit consists of a fusible element, an arcing rod, and a solid-material arc-extinguishing medium contained within a filament-wound glass-epoxy tube. See **Figure 8**.

One end of the fusible element is connected, through the current-transfer bridge, to the exhaust ferrule. The other end is connected to the arcing rod, which extends upward through the stepped bore of the fuse unit. A drive spring inside the fuse unit provides the stored energy to drive the arcing rod upward, through the arc-extinguishing medium, during fault-current interruption. The actuating pin at the upper end of the spring-driven arcing rod initiates dropout action by penetrating the fuse-unit upper seal and tripping the upper-live-part latch. See **Figure 9 on page 12 through Figure 11 on page 13**.

The SMU-20 Fuse Unit is designed for universal use. It's also used in underground applications in S&C PMH and PME Pad-Mounted Gear and in Custom Metal-Enclosed Switchgear.

**FIGURE 8.** An inside view of the SMU-20 Fuse Unit.



## THE FUSIBLE ELEMENT

SMU-20 Fuse Units are available in a wide variety of ampere ratings and TCC curves, permitting close fusing to achieve maximum protection and optimum coordination. With the initial and sustained accuracy of their melting time-current characteristics, SMU-20 Fuse Units can be relied upon to operate exactly when they should and—equally important—not to operate when they shouldn't. This permanent accuracy is achieved principally in the design and construction of the fusible element.

## NONDAMAGEABLE CONSTRUCTION

SMU-20 Fuse Units have silver or pretensioned nickel-chrome fusible elements that are drawn through precision dies to very accurate diameters and are of solderless construction, brazed into their terminals. Melting TCC curves are precise, with only 10% total tolerance in melting current, compared to the 20% tolerance of most fuses.

The design and construction features of the fusible elements ensure they will conform to their TCC curves not only initially but on a sustained basis. They're corrosion-resistant and nondamageable. Neither age, vibration, nor surges

that heat the element nearly to the severing point will affect the characteristics of these fuses.

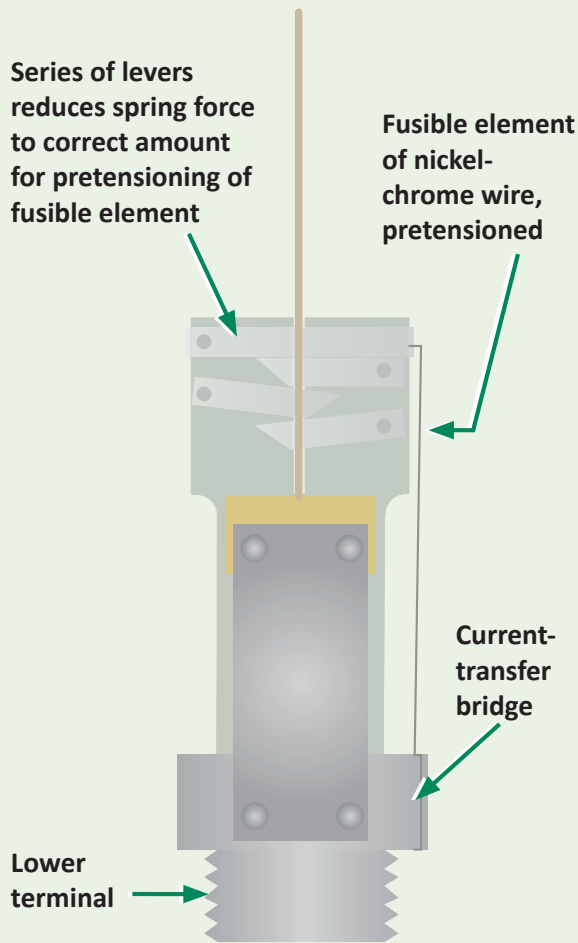
S&C's fusible elements are nondamageable and provide these advantages:

- ◆ **Superior transformer protection.** With SMU-20 Fuse Units, it's possible to fuse close to transformer full-load current, thus providing protection against a broad range of secondary-side faults.
- ◆ **Heightened service continuity.** "Sneak-outs" (unnecessary fuse operations) are eliminated.
- ◆ **Close coordination with other overcurrent protective devices.** This is attained because of the initial and sustained precision of the fusible elements and because no "safety zones" or "setback allowances" need be applied to the published TCC curves to protect the element against damage.
- ◆ **Operating economies.** There's no need to replace unblown companion fuses on suspicion of damage following a fuse operation. See **Figure 9 and Figure 10 on page 12** and **Figure 11 on page 13**.

# The SMU-20<sup>®</sup> Fuse Unit (continued)

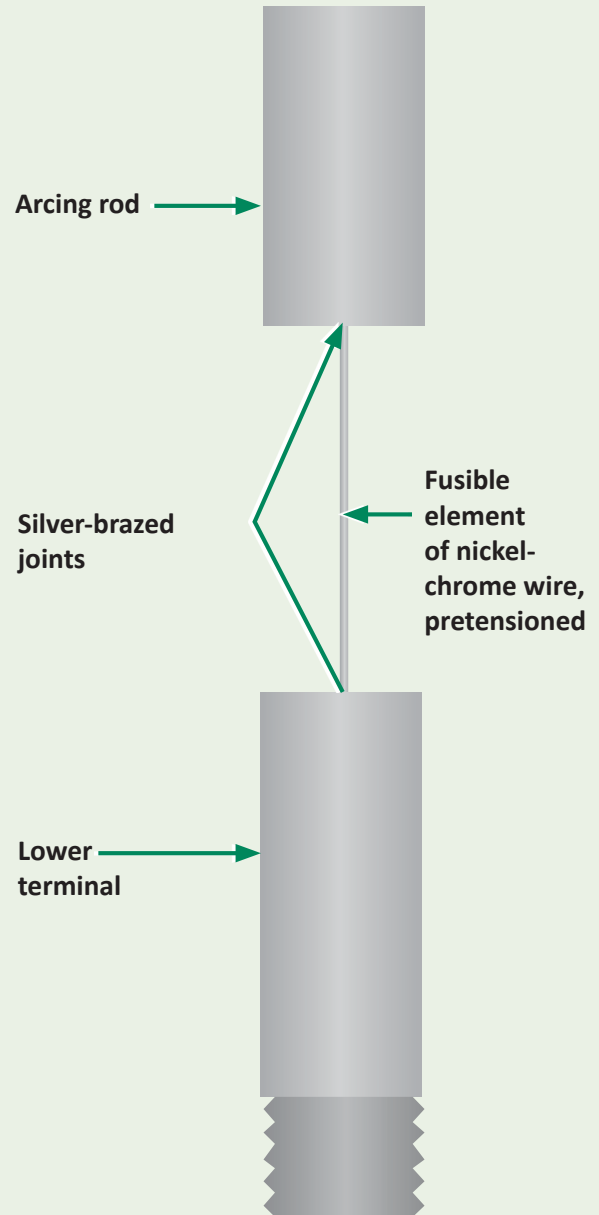
**FIGURE 9.** Nondamageable low-current, nickel-chrome fusible element for fuse unit rated 1 ampere.

In this rating, the nickel-chrome wire is too fine to withstand the full force of the spring. An assembly of levers in effect multiplies the tensile strength of the wire to permit the desired pretensioning without jeopardizing the security of the fusible element.



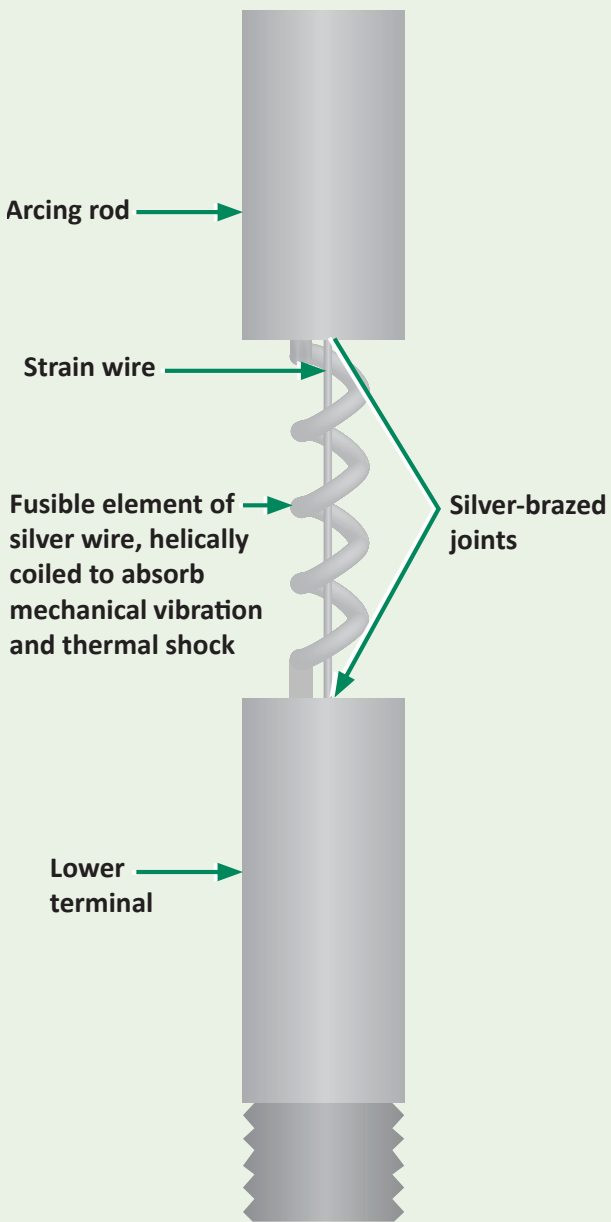
**FIGURE 10.** Nondamageable nickel-chrome fusible element for fuse units rated 5E and 7E amperes.

When called upon to operate, the pretensioned nickel-chrome wire weakens abruptly and separates before its cross-section changes.



**FIGURE 11.** Nondamageable silver fusible element for fuse units rated 10E amperes and larger.

These ratings use the silver fusible element, strain-wire construction, which is not damaged by overloads or transient faults approaching the minimum melting current.



# Features

## FAULT INTERRUPTION

Fast, positive fault interruption is achieved in the SMU-20 Fuse Unit—after the fusible element melts—through both:

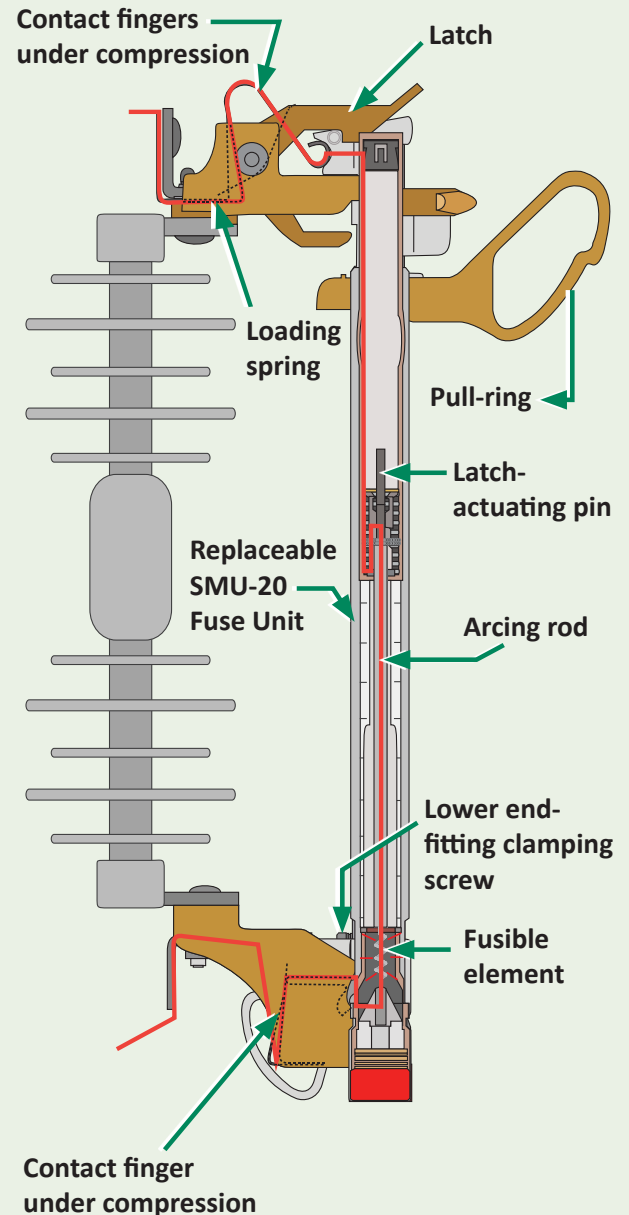
- ◆ High-speed elongation of the arc in the solid-material-lined bore (as produced by rapid movement of the spring-driven arcing rod)
- ◆ Efficient deionizing action of the gases generated through thermal reaction of the solid material caused by the heat of the confined arc

## POSITIVE DROPOUT ACTION

When the fuse unit is blown, the force of the drive spring causes the latch-actuating pin at the upper end of the arcing rod to penetrate the fuse-unit upper seal and lift the latch above the roller on the upper end-fitting.

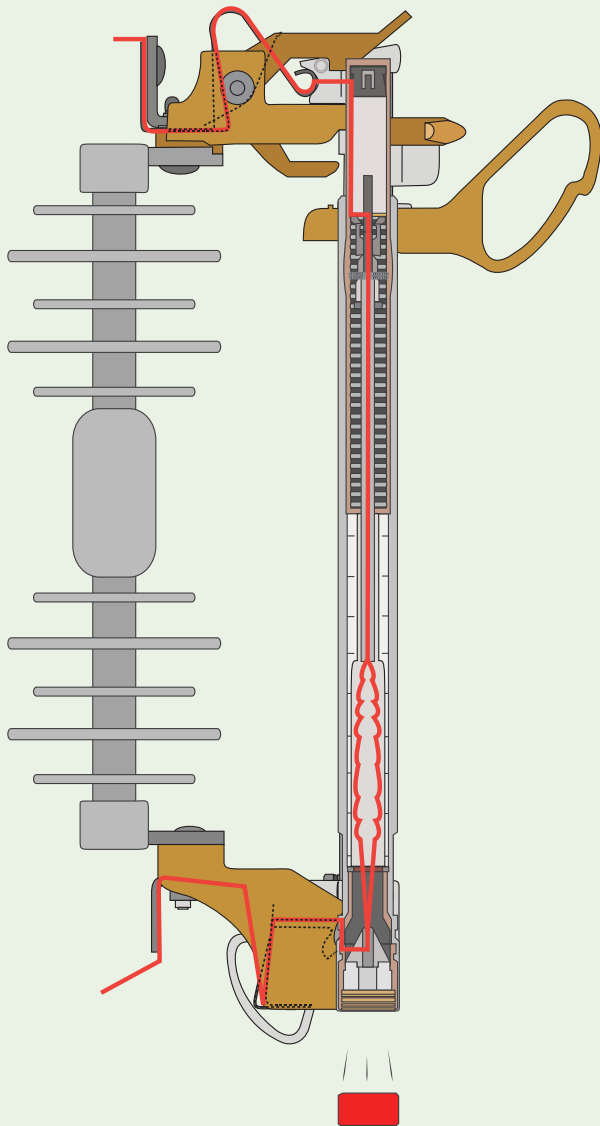
After the roller is free of the latch, the spring-backed contact fingers thrust the fuse unit outward, permitting it to swing (by force of gravity) to the fully Open position. See **Figure 12**, and **Figure 13** and **Figure 14** on page 15.

**FIGURE 12.** Overcurrent melts the silver fusible element and then transfers to the strain wire, which volatilizes instantly. Arcing is initiated as shown.

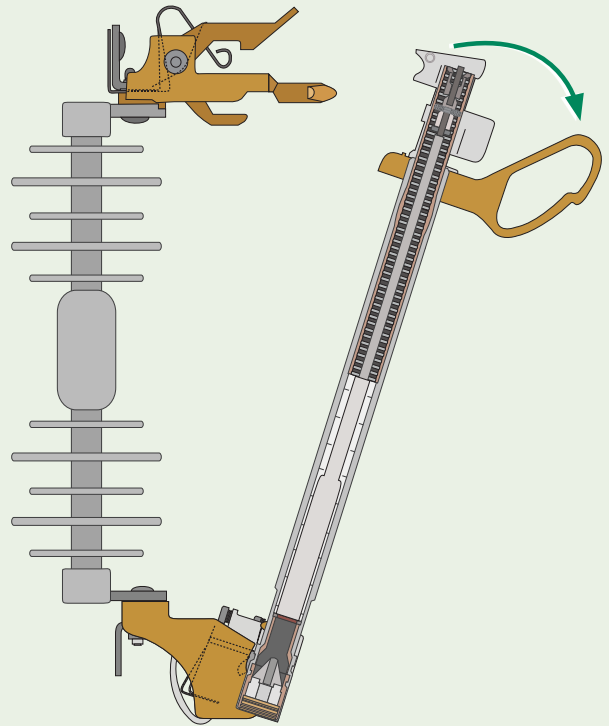


**FIGURE 13.** Released force of the drive spring thrusts the arcing rod upward, causing rapid elongation of the arc in the solid-material lined bore of the fuse unit.

Under maximum fault conditions, heat from the confined arc causes the solid material in the large-diameter section of the arc-extinguishing chamber to undergo a thermal reaction—generating turbulent gases and effectively enlarging the bore diameter so the arc energy is released with a mild exhaust. Under low to moderate fault conditions, the arc is extinguished in the upper section of the arc-extinguishing chamber, where the small-diameter bore effectively concentrates the deionizing gases for reliable arc extinction.



**FIGURE 14.** Continued upward travel of the arcing rod after arc extinction causes the actuating pin to penetrate the upper seal and to initiate positive dropout of the blown SMU-20 Fuse Unit.

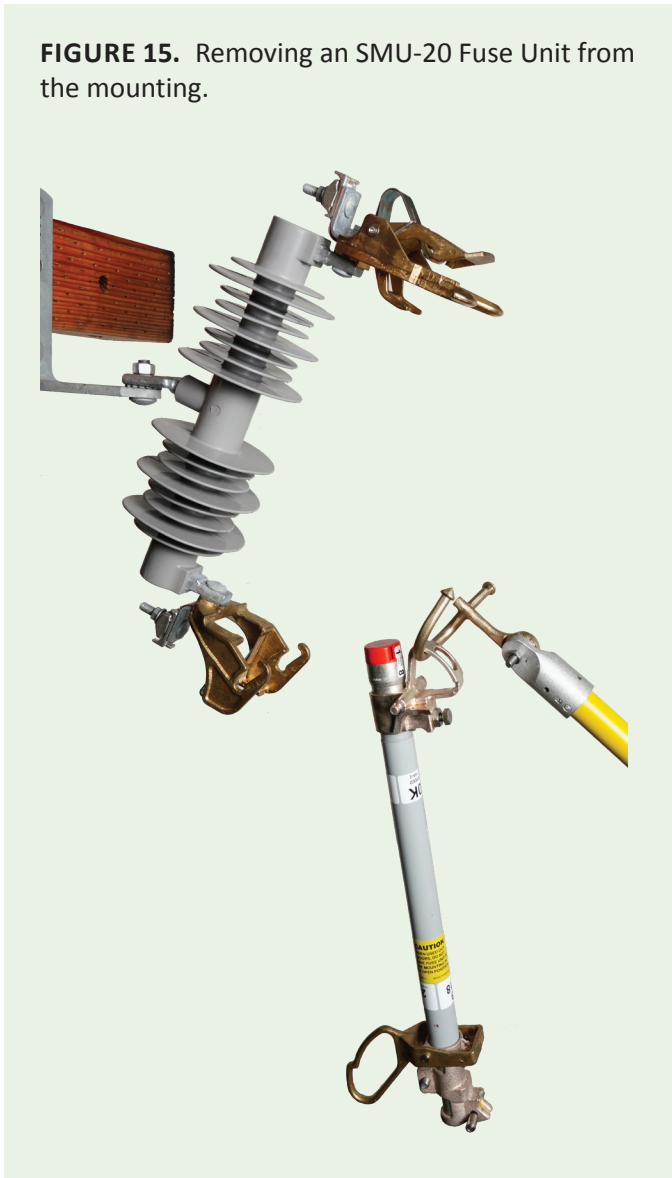


### EASY TO HANDLE

When the SMD-20 Power Fuse operates, the SMU-20 Fuse Unit swings to the Open position. It can be easily removed by inserting a hotstick into the lifting ring of the lower end-fitting. Replacement is equally easy. See **Figure 15**.

The fuse-unit end-fittings are reusable and are readily removed from the blown fuse and re-installed on a new SMU-20 Fuse Unit. The replacement fuse unit with end-fittings is simply lowered into the hinge and closed, as described in **Figure 16 on page 17**.

**FIGURE 15.** Removing an SMU-20 Fuse Unit from the mounting.



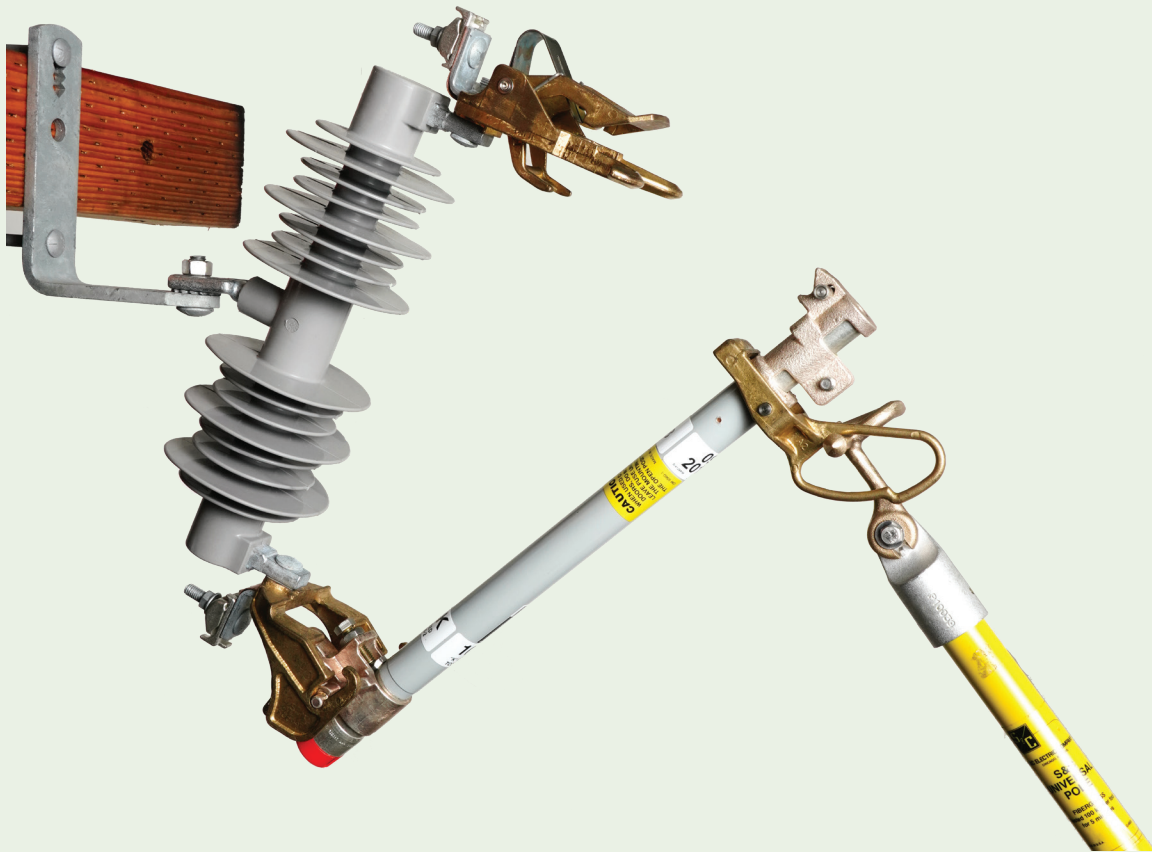
### EASY TO CLOSE

SMD-20 Power Fuses may be closed using a hotstick from practically any angle. At the start of the closing operation, the SMU-20 Fuse Unit is laterally restrained by engagement of guiding surfaces on the hinge with substantial trunnions and cams on the lower end-fitting. Loadbuster tool attachment hooks guide the upper end-fitting into proper alignment for latching at the end of the closing operation.

During closing, the fuse unit is brought to within several inches of the upper live parts and then, while looking away, is fully closed with a purposeful thrust. See **Figure 16**. The Loadbuster tool attachment hooks guide the fuse unit during the final approach into the upper-contact assembly.



FIGURE 16. Closing the fuse unit.



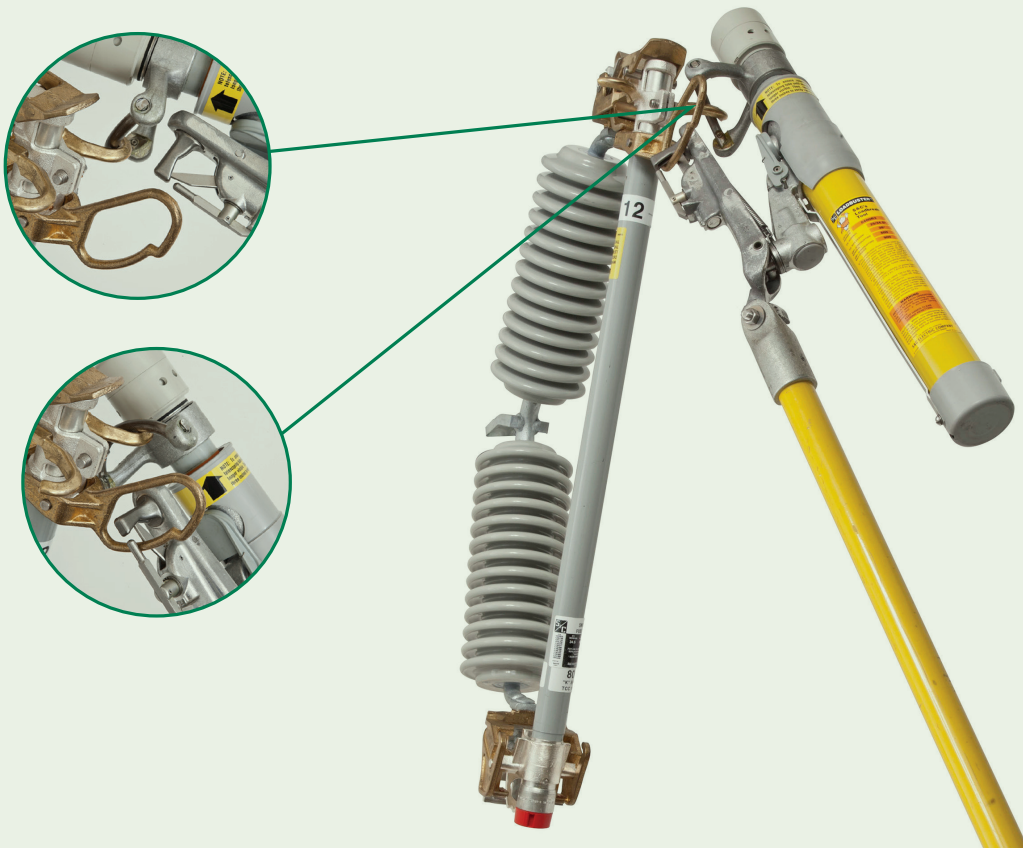
# Easy to Operate with Loadbuster— The S&C Loadbreak Tool

All SMD-20 Power Fuses are equipped with hooks so they may be operated with Loadbuster—The S&C Loadbreak Tool to provide full-load switching at maximum system voltage, as well as switching of associated magnetizing and line-charging currents. There's no need to install a disconnect (isolator) or interrupter switch in series with the fuse, thus providing greatly improved appearance and an immediate cost savings. Moreover, because the interrupting unit is in the Loadbuster tool—and because only one Loadbuster tool is needed for each truck—the advantages of low-cost, universal load switching are available anywhere on the distribution system.

Switching with the Loadbuster tool is a quick and simple operation. See **Figure 17**. Circuit interruption occurs internally, without any external arc or flame. The only sound is that of the Loadbuster tool tripping. Because circuit interruption is independent of the speed with which the Loadbuster tool is operated, all that's required is a smooth operating stroke—without hesitation—until the tool is extended to its maximum length. The resetting latch retains the tool in the Open position for removal from the power fuse.

**FIGURE 17.** Switching with the Loadbuster tool.

**Attach:** Reach across the front of the SMD-20 Power Fuse and attach the Loadbuster tool's anchor to the attachment hook on the far side of the fuse mounting. Then, engage the pull-ring with the Loadbuster tool's pull-ring hook. The Loadbuster tool's pull-ring latch prevents inadvertent disengagement.

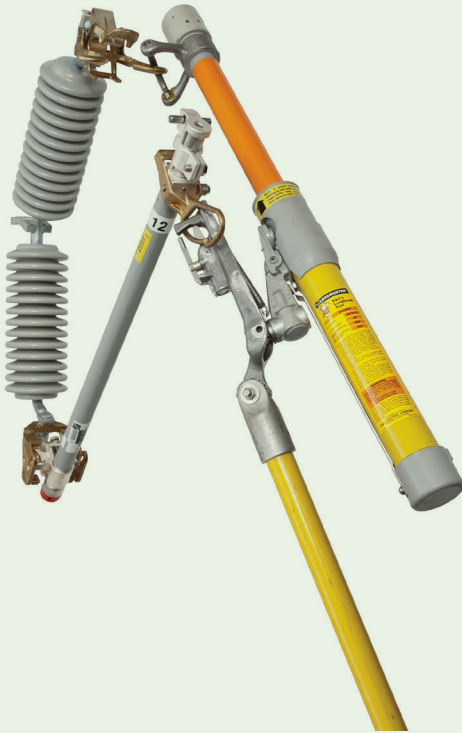


## Easy to Operate with Loadbuster— The S&C Loadbreak Tool (continued)

Resetting the Loadbuster tool is easy. Just release the resetting latch and firmly close the extended tool to its fully telescoped position. See **Figure 18** and **Figure 19**. For detailed information on the Loadbuster tool, see S&C Descriptive Bulletin 811-30.

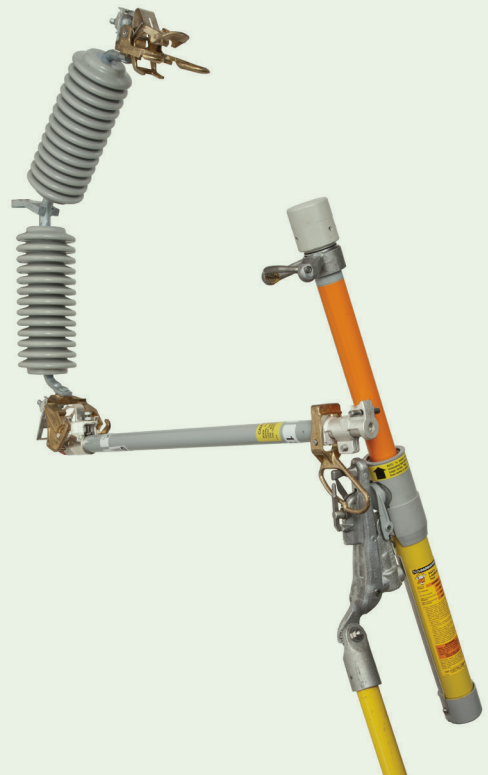
**FIGURE 18.** Load-current switching with the Loadbuster tool.

**Pull:** A firm, steady downward pull on the Loadbuster tool—to its maximum extended length—opens the SMD-20 Power Fuse in the normal manner and breaks the circuit positively.



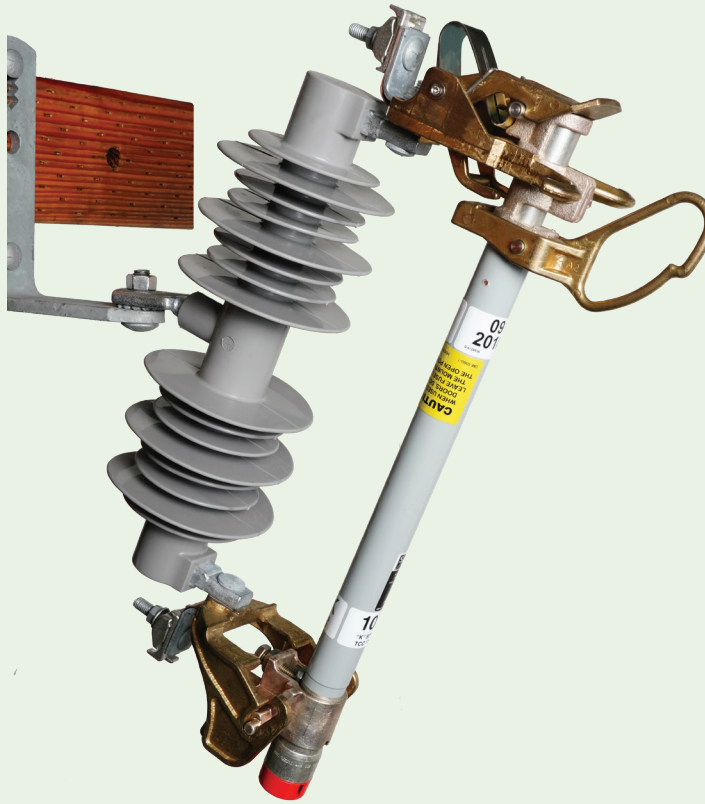
**FIGURE 19.** Disengaging the Loadbuster tool after a switching operation.

**Remove:** To disengage the Loadbuster tool, remove its anchor from the attachment hook. Then, with the fuse in the fully Open position, use a “roll-off” movement to disengage from the pull-ring. The Loadbuster tool is easily reset for the next opening operation.



# Mounting Styles and Ratings

**FIGURE 20.** 14.4-kV Overhead—Pole-Top Style



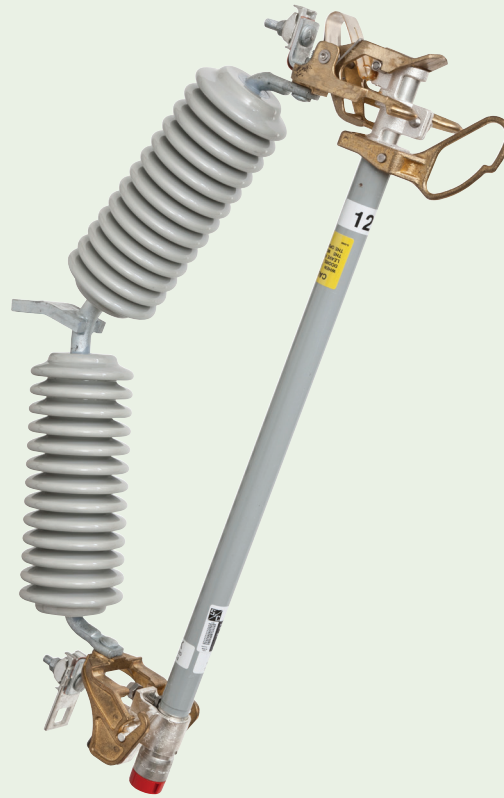
**TABLE 1.** 50/60-Hz Ratings for 14.4-kV and 25-kV Overhead—Pole-Top Style SMD-20 Power Fuses

Nom. (kV)	Max (kV)	BIL	Max <sup>1</sup> (Amperes, RMS)	Interrupting (Sym.), (Amperes, RMS) 50 Hz	Interrupting <sup>2</sup> (Sym.), (Amperes, RMS) 60 Hz	Polymer Insulators, in inches (mm)	Porcelain Insulators, in inches (mm)
14.4	17.0	125	200E	11 200	14 000	—	11 (279)
14.4	17.0	150	200E	11 200	14 000	26½ (673)	17 (432)
25	27	150	200E	10 000	12 500	—	17 (432)
25	27	150	200E	10 000	12 500	37½ (953)	26 (660)

- SMU-20 Fuse Units used with these power fuses are available in ratings through 200K amperes as well as 200E amperes.
- Refer to S&C Data Bulletin 201-190 for detailed interrupting ratings.

## Mounting Styles and Ratings (continued)

**FIGURE 21.** 34.5-kV Overhead—Pole-Top Style



**TABLE 2.** 50/60-Hz Ratings for 34.5-kV Overhead—Pole-Top Style SMD-20 Power Fuses

Nom. (kV)	Max (kV)	BIL (kV)	Max <sup>1</sup> (Amperes, RMS)	Interrupting <sup>2</sup> (Sym.), (Amperes, RMS) 50 Hz	Interrupting (Sym.), (Amperes, RMS) 60 Hz	Minimum Leakage Distance to Ground, in Inches (mm)
14.4	17.0	125	200E	11 200	14 000	11 (279)
14.4	17.0	150	200E	11 200	14 000	11 (279)
25	27	150	200E	10 000	12 500	17 (432)
34.5	38	200	200E	10 000	10 000	25½ (648)

- 1 SMU-20 Fuse Units used with these power fuses are available in ratings through 200K amperes as well as 200E amperes.  
 2 Refer to S&C Data Bulletin 201-190 for detailed interrupting ratings.

# Mounting Styles and Ratings (continued)

**FIGURE 22.** 14.4-kV Station—Vertical-Offset Style



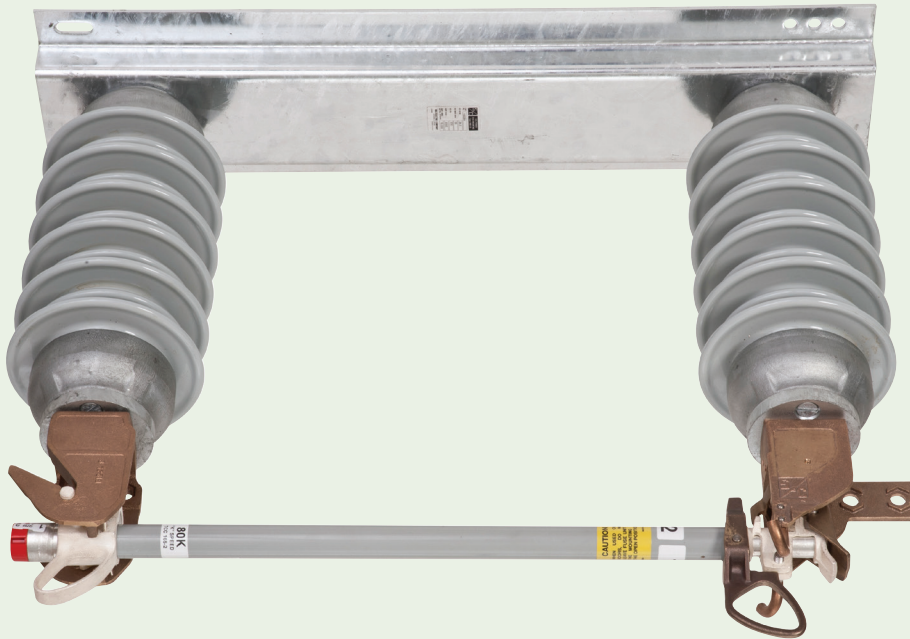
**TABLE 3.** 50/60-Hz Ratings for Station—Vertical-Offset Style SMD-20 Power Fuses

Nom. (kV)	Max (kV)	BIL (kV)	Max <sup>1</sup> (Amperes, RMS)	Interrupting <sup>2</sup> (Sym.), (Amperes, RMS) 50 Hz	Interrupting (Sym.), (Amperes, RMS) 60 Hz	Minimum Leakage Distance to Ground, in Inches (mm)
14.4	17.0	110	200E	11 200	14 000	15½ (394)
25	27	150	200E	10 000	12 500	24 (610)
34.5	38	200	200E	8 000	10 000	37 (940)

1 SMU-20 Fuse Units used with these power fuses are available in ratings through 200K amperes as well as 200E amperes.

2 Refer to S&C Data Bulletin 201-190 for detailed interrupting ratings.

**FIGURE 23.** 34.5-kV Station—Inverted Style



**TABLE 4.** 50/60-Hz Ratings for Station—Inverted Style SMD-20 Power Fuses

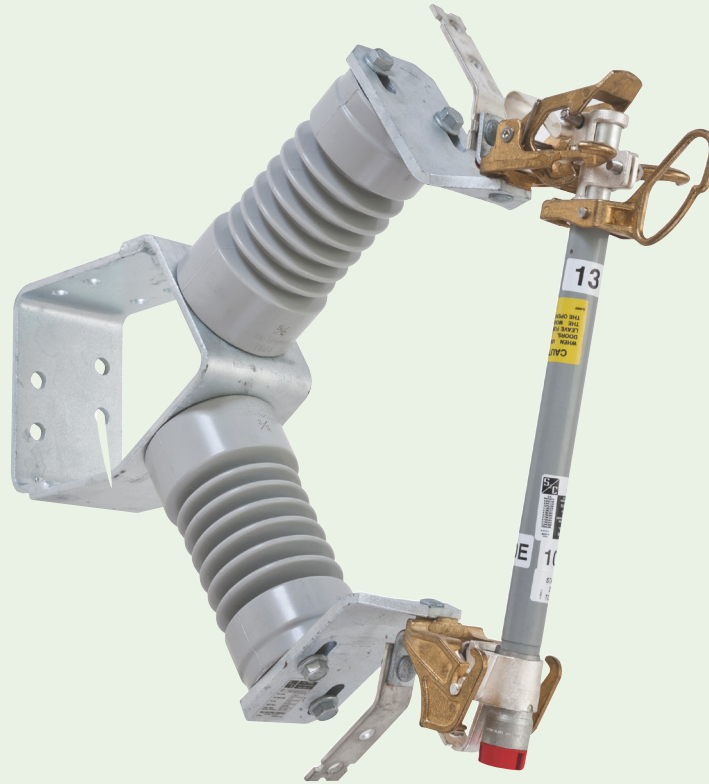
Nom. (kV)	Max (kV)	BIL (kV)	Max <sup>1</sup> (Amperes, RMS)	Interrupting <sup>2</sup> (Sym.), (Amperes, RMS) 50 Hz	Interrupting (Sym.), (Amperes, RMS) 60 Hz	Minimum Leakage Distance to Ground, in Inches (mm)
14.4	17.0	110	200E	11 200	14 000	15½ (394)
25	27	150	200E	10 000	12 500	24 (610)
34.5	38	200	200E	8 000	10 000	37 (940)

1 SMU-20 Fuse Units used with these power fuses are available in ratings through 200K amperes as well as 200E amperes.

2 Refer to S&C Data Bulletin 201-190 for detailed interrupting ratings.

## Mounting Styles (continued)

**FIGURE 24.** 14.4-kV Station—Right-Angle Style



**TABLE 5.** 50/60-Hz Ratings for Station—Right-Angle Style SMD-20 Power Fuses

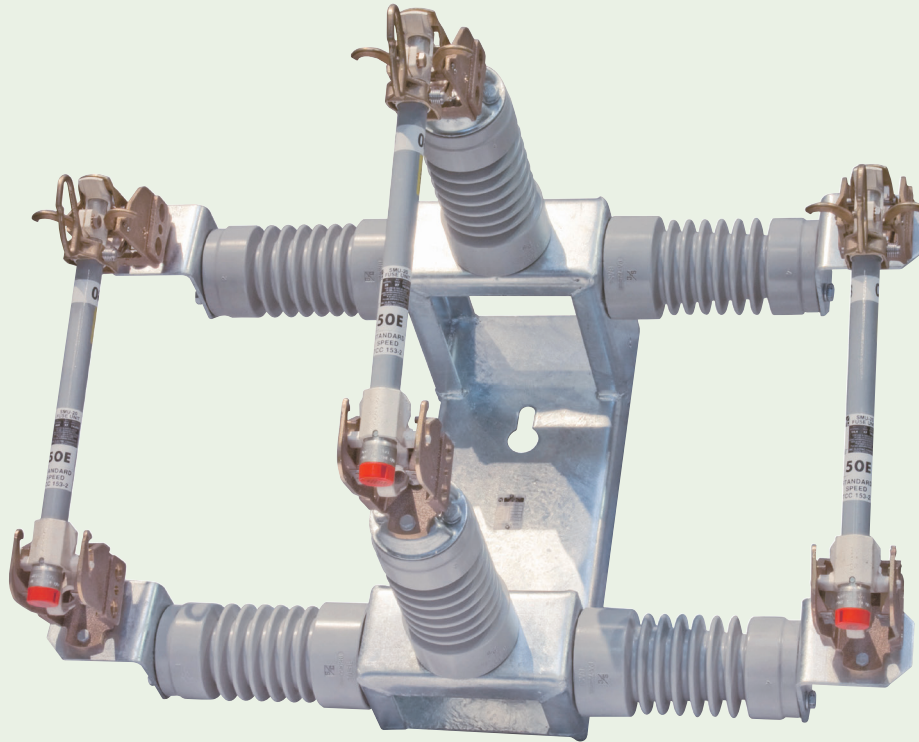
Nom. (kV)	Max (kV)	BIL (kV)	Max <sup>1</sup> (Amperes, RMS)	Interrupting <sup>2</sup> (Sym.), (Amperes, RMS) 50 Hz	Interrupting (Sym.), (Amperes, RMS) 60 Hz	Minimum Leakage Distance to Ground, in Inches (mm)
14.4	17.0	110	200E	11 200	14 000	15½ (394)
25	27	150	200E	10 000	12 500	24 (610)
34.5	38	200	200E	8 000	10 000	37 (940)

1 SMU-20 Fuse Units used with these power fuses are available in ratings through 200K amperes as well as 200E amperes.

2 Refer to S&C Data Bulletin 201-190 for detailed interrupting ratings.



**FIGURE 25.** 14.4-kV Station—Cluster-Offset Style



**TABLE 6.** 50/60-Hz Ratings for Station—Cluster-Offset Style SMD-20 Power Fuses

Nom. (kV)	Max (kV)	BIL (kV)	Max <sup>1</sup> (Amperes, RMS)	Interrupting <sup>2</sup> (Sym.), (Amperes, RMS) 50 Hz	Interrupting (Sym.), (Amperes, RMS) 60 Hz	Minimum Leakage Distance to Ground, in Inches (mm)
14.4	17.0	110	200E	11 200	14 000	15½ (394)
25	27	150	200E	10 000	12 500	24 (610)
34.5	38	200	200E	8 000	10 000	37 (940)

- 1 SMU-20 Fuse Units used with these power fuses are available in ratings through 200K amperes as well as 200E amperes.
- 2 Refer to S&C Data Bulletin 201-190 for detailed interrupting ratings.



**CONTACT YOUR S&C SALES  
REPRESENTATIVE FOR  
MORE INFORMATION**

[sandc.com](http://sandc.com)

