

S&C Circuit-Switchers — Mark V★
Outdoor Transmission
(34.5 kV through 345 kV)

Typical Tripping Scheme with Overcurrent Blocking
for Circuit-Switchers with Shunt-Trip Device, Used in
Transformer Protection Applications

SINGLE-LINE DIAGRAM

(Wiring to be furnished by user)

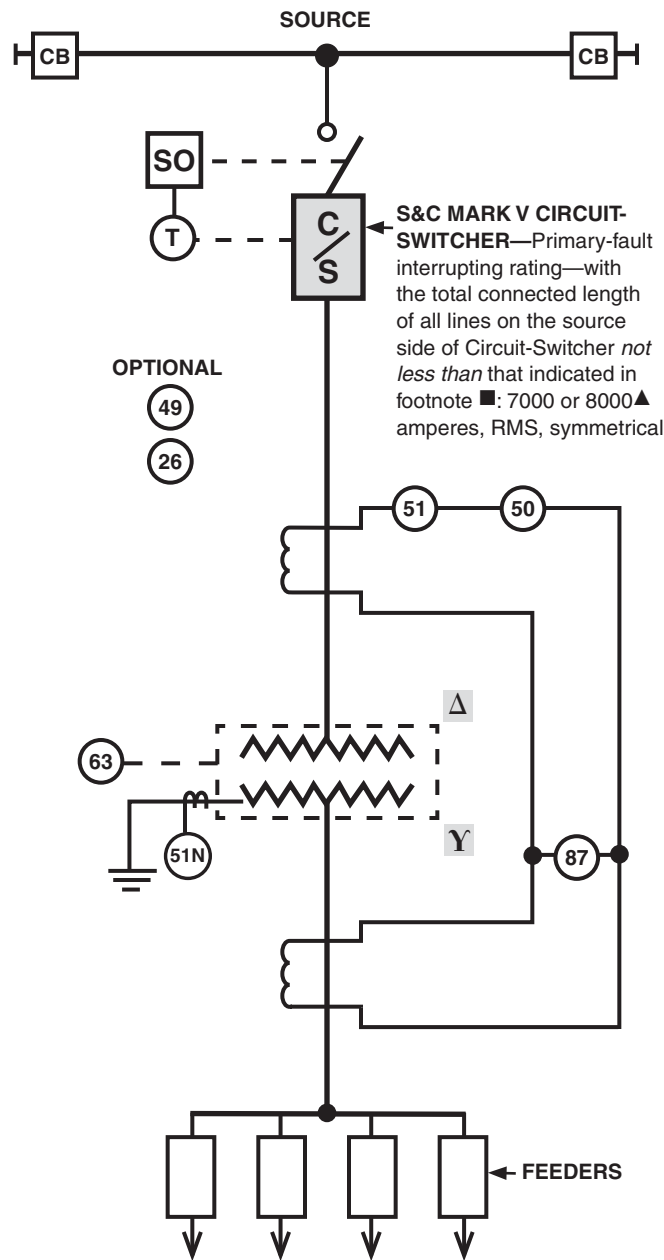

CONTROL SCHEMATIC DIAGRAM◆

(Wiring to be furnished by user)

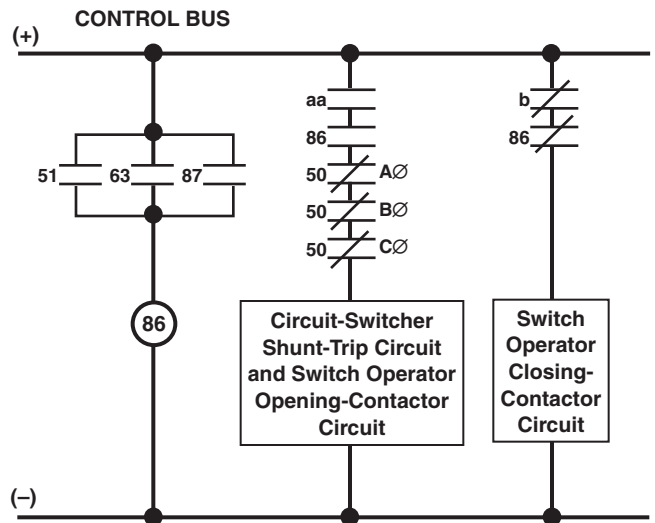

Symbols

- SO** S&C Switch Operator
- T** S&C Circuit-Switcher shunt-trip solenoid
- aa** Late-opening “a” contact of S&C Switch Operator
- b** Auxiliary contact of S&C Switch Operator
- 26** Optional thermal device
- 49** Optional thermal overload
- 50** Instantaneous overcurrent relay, plunger type (set at 90% of the Circuit-Switcher primary-fault interrupting rating; i.e., 6300-ampere pickup for Circuit-Switchers with 7000-ampere primary-fault interrupting rating, or 7200-ampere pickup for Circuit-Switchers with 8000-ampere primary-fault interrupting rating)
- 51** Inverse-time overcurrent relay, induction type
- 51N** Neutral ground fault relay
- 63** Sudden-pressure relay
- 86** Auxiliary relay, electrically latched, manually reset
- 87** Differential overcurrent relay, induction type

■ Total connected length of all overhead lines (in all directions), including any number of feeders connected to source-side substations, as indicated in table below. (Connected cable may reduce or eliminate the line-length requirement. Refer to the nearest S&C Sales Office.)

System Voltage, kV →	34.5 thru 69	115 and 138	161	230	345
Total Length, Miles →	7	15	20	25	40

▲ 8000 amperes for all Mark V Circuit-Switcher models rated 34.5 kV through 69 kV, also 2-gap models rated 115 kV and 3-gap models rated 138 kV and 161 kV; 7000 amperes for all other Mark V Circuit-Switchers for which application symbol “J” applies. 8000 amperes for 230-kV and 345-kV, 6-gap Mark IV Circuit-Switchers. (Earlier Circuit-Switcher designs may have different primary-fault interrupting ratings. Refer to the nearest S&C Sales Office.)

◆ Circuit-Switcher and switch operator shown in the open position; 86 relay shown reset.

★ Also applicable to Mark III and Mark IV Circuit-Switchers.



Operating Description

One or both of the fault-current relays (51 and/or 87) will operate, after an inverse-time delay, for all values of fault current. The sudden-pressure relay (63) will operate instantaneously in the event of a rapid change of pressure within the transformer.

Operation of any of these fault-detecting relays will actuate the auxiliary relay (86). This, in turn, will energize the Circuit-Switcher shunt-trip circuit and switch operator opening-contactor circuit, unless the current exceeds the pickup setting of the instantaneous overcurrent relays (50). (The auxiliary relay will remain in the “operated” position—held by a mechanical latch—until manually reset, preventing the switch operator from being closed.)

For fault currents exceeding the overcurrent-relay pickup setting, one or more of the overcurrent relays (50) will operate instantaneously, blocking the Circuit-Switcher shunt-trip circuit and switch operator opening-contactor circuit. After the fault has been cleared by the source-side protective equipment, the overcurrent relays (50) will restore, energizing the Circuit-Switcher shunt-trip circuit and switch operator opening-contactor circuit.

Relay Coordination Data

For Mark V Circuit-Switchers equipped with the optional S&C Shunt-Trip Device, the maximum interrupting time is 8 cycles (on a 60-hertz basis, starting from energization of the trip circuit by the user’s protective-relay contacts). The minimum opening time (time from energization of the Circuit-Switcher’s trip circuit to parting of the interrupting-unit contacts) is 3.7 cycles when the shunt-trip solenoids are energized directly; or 4.9 cycles when the shunt-trip solenoids are energized through the switch operator’s shunt-trip solenoid (94) switch. The shunt-trip solenoid (94) switch (which limits inrush current by energizing the shunt-trip solenoids and the switch-operator motor in sequence, thus permitting use of minimum-size control wires), as well as a redundant (62) relay (which functions as a backup, ensuring Circuit-Switcher opening independent of shunt-trip operation) are included in switch operators with Catalog Number Suffix “-HP.”